



Long Term Evolution (LTE): A Technical Overview





Introduction

The recent increase of mobile data usage and emergence of new applications such as MMOG (Multimedia Online Gaming), mobileTV, Web 2.0, streaming contents have motivated the 3rd Generation Partnership Project (3GPP) to work on the Long-Term Evolution (LTE). LTE is the latest standard in the mobile network technology tree that previously realized the GSM/EDGE and UMTS/HSPA network technologies that now account for over 85% of all mobile subscribers. LTE will ensure 3GPP's competitive edge over other cellular technologies.

LTE, whose radio access is called Evolved UMTS Terrestrial Radio Access Network (E-UTRAN), is expected to substantially improve end-user throughputs, sector capacity and reduce user plane latency, bringing significantly improved user experience with full mobility. With the emergence of Internet Protocol (IP) as the protocol of choice for carrying all types of traffic, LTE is scheduled to provide support for IP-based traffic with end-to-end Quality of service (QoS). Voice traffic will be supported mainly as Voice over IP (VoIP) enabling better integration with other multimedia services. Initial deployments of LTE are expected by 2010 and commercial availability on a larger scale 1-2 years later.

Unlike HSPA (High Speed Packet Access), which was accommodated within the Release 99 UMTS architecture, 3GPP is specifying a new Packet Core, the Evolved Packet Core (EPC) network architecture to support the E-UTRAN through a reduction in the number of network elements, simpler functionality, improved redundancy but most importantly allowing for connections and hand-over to other fixed line and wireless access technologies, giving the service providers the ability to deliver a seamless mobility experience

LTE has been set aggressive performance requirements that rely on physical layer technologies, such as, Orthogonal Frequency Division Multiplexing (OFDM) and Multiple-Input Multiple-Output (MIMO) systems, Smart Antennas to achieve these targets. The main objectives of LTE are to minimize the system and User Equipment (UE) complexities, allow flexible spectrum deployment in existing or new frequency spectrum and to enable co-existence with other 3GPP Radio Access Technologies (RATs).

LTE is backed by most 3GPP and 3GPP2 service providers who along with the other interested parties aim to complete and agree the EUTRAN Standards by Q4-2007 and the EPC by Q1-2008.

PERFORMANCE GOALS FOR LTE

E-UTRA is expected to support different types of services including web browsing, FTP, video streaming, VoIP, online gaming, real time video, push-to-talk and push-to-view. Therefore, LTE is being designed to be a high data rate and low latency system as indicated by the key performance criteria shown in Table 1. The bandwidth capability of a UE is expected to be 20MHz for both transmission and reception. The service provider can however deploy cells with any of the bandwidths listed in the table. This gives flexibility to the service providers' to tailor their offering dependent on the amount of available spectrum or the ability to start with limited spectrum for lower upfront cost and grow the spectrum for extra capacity.

Beyond the metrics LTE is also aimed at minimizing cost and power consumption while ensuring backward-compatibility and a cost effective migration from UMTS systems. Enhanced multicast services, enhanced support for end-to-end Quality of Service (QoS) and minimization of the number of options and redundant features in the architecture are also being targeted. The spectral efficiency in the LTE DownLink (DL) will be 3 to 4 times of that of Release 6 HSDPA while in the UpLink (UL), it will be 2 to 3 times that of Release 6 HSUPA. The handover procedure within LTE is intended to minimize interruption time to less than that of circuit-switched handovers in 2G networks. Moreover the handovers to 2G/3G systems from LTE are designed to be seamless.

Table 1: LTE performance requirements

Metric	Requirement
Peak data rate	DL: 100Mbps UL: 50Mbps (for 20MHz spectrum)
Mobility support	Up to 500kmph but optimized for low speeds from 0 to 15kmph
Control plane latency (Transition time to active state)	< 100ms (for idle to active)
User plane latency	< 5ms
Control plane capacity	> 200 users per cell (for 5MHz spectrum)
Coverage (Cell sizes)	5 – 100km with slight degradation after 30km
Spectrum flexibility	1.25, 2.5, 5, 10, 15, and 20MHz

System Architecture Description

To minimize network complexity, the currently agreed LTE architecture is as shown in Figure 1 [2, 3].

Functional Elements

The architecture consists of the following functional elements:

Evolved Radio Access Network (RAN)

The evolved RAN for LTE consists of a single node, i.e., the eNodeB (eNB) that interfaces with the UE. The eNB hosts the PHYSical (PHY), Medium Access Control (MAC), Radio Link Control (RLC), and Packet Data Control Protocol (PDCP) layers that include the functionality of user-plane header-compression and encryption. It also offers Radio Resource Control (RRC) functionality corresponding to the control plane. It performs many functions including radio resource management, admission control, scheduling, enforcement of negotiated UL QoS, cell information broadcast, ciphering/deciphering of user and control plane data, and compression/decompression of DL/UL user plane packet headers.

Serving Gateway (SGW)

The SGW routes and forwards user data packets, while also acting as the mobility anchor for the user plane during inter-eNB handovers and as the anchor for mobility between LTE and other 3GPP technologies (terminating S4 interface and relaying the traffic between 2G/3G systems and PDN GW). For idle state UEs, the SGW terminates the DL data path and triggers paging when DL data arrives for the UE. It manages and stores UE contexts, e.g. parameters of the IP bearer service, network internal routing information. It also performs replication of the user traffic in case of lawful interception.

Mobility Management Entity (MME)

The MME is the key control-node for the LTE access-network. It is responsible for idle mode UE tracking and paging procedure including retransmissions. It is involved in the bearer activation/deactivation process and is also responsible for choosing the SGW for a UE at the initial attach and at time of intra-LTE handover involving Core Network (CN) node relocation. It is responsible for authenticating the user (by interacting with the HSS). The Non-Access Stratum (NAS) signaling terminates at the MME and it is also responsible for generation and allocation of temporary identities to UEs. It checks the authorization of the UE to camp on the service provider's Public Land Mobile Network (PLMN) and enforces UE roaming restrictions. The MME is the

termination point in the network for ciphering/integrity protection for NAS signaling and handles the security key management. Lawful interception of signaling is also supported by the MME. The MME also provides the control plane function for mobility between LTE and 2G/3G access networks with the S3 interface terminating at the MME from the SGSN. The MME also terminates the S6a interface towards the home HSS for roaming UEs.

Packet Data Network Gateway (PDN GW)

The PDN GW provides connectivity to the UE to external packet data networks by being the point of exit and entry of traffic for the UE. A UE may have simultaneous connectivity with more than one PDN GW for accessing multiple PDNs. The PDN GW performs policy enforcement, packet filtering for each user, charging support, lawful interception and packet screening. Another key role of the PDN GW is to act as the anchor for mobility between 3GPP and non-3GPP technologies such as WiMAX and 3GPP2 (CDMA 1X and EvDO).

Key Features

EPS to EPC

A key feature of the EPS is the separation of the network entity that performs control-plane functionality (MME) from the network entity that performs bearer-plane functionality (SGW) with a well defined open interface between them (S11). Since E-UTRAN will provide higher bandwidths to enable new services as well as to improve existing ones, separation of MME from SGW implies that SGW can be based on a platform optimized for high bandwidth packet processing, whereas the MME is based on a platform optimized for signaling transactions. This enables selection of more cost-effective platforms for, as well as independent scaling of, each of these two elements. Service providers can also choose optimized topological locations of SGWs within the network independent of the locations of MMEs in order to optimize bandwidth reduce latencies and avoid concentrated points of failure.

S1-flex Mechanism

The S1-flex concept provides support for network redundancy and load sharing of traffic across network elements in the CN, the MME and the SGW, by creating pools of MMEs and SGWs and allowing each eNB to be connected to multiple MMEs and SGWs in a pool.

Network Sharing

The LTE architecture enables service providers to reduce the cost of owning and operating the network by allowing the service providers to have separate CN (MME, SGW, PDN GW) while the E-UTRAN (eNBs) is jointly shared by them. This is enabled by the S1-flex mechanism by enabling each eNB to be connected to multiple CN entities. When a UE attaches to the network, it is connected to the appropriate CN entities based on the identity of the service provider sent by the UE.

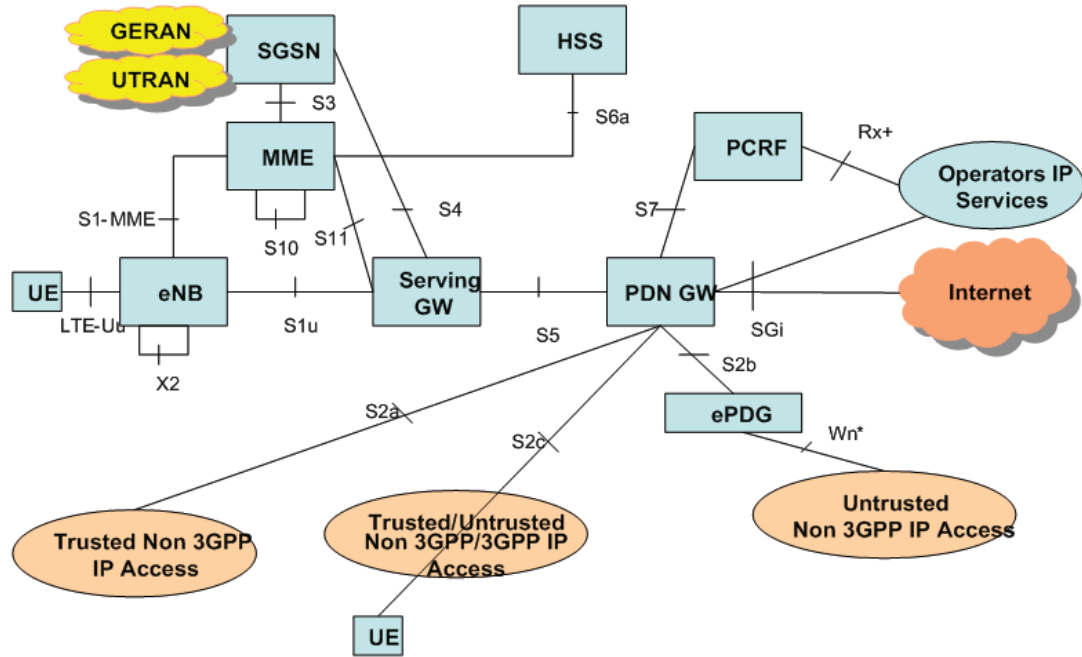

(Untrusted non-3GPP access requires ePDG in the data path)

Figure 1: High level architecture for 3GPP LTE (Details of all LTE interfaces are given in Appendix A)

PROTOCOL LAYER ARCHITECTURE

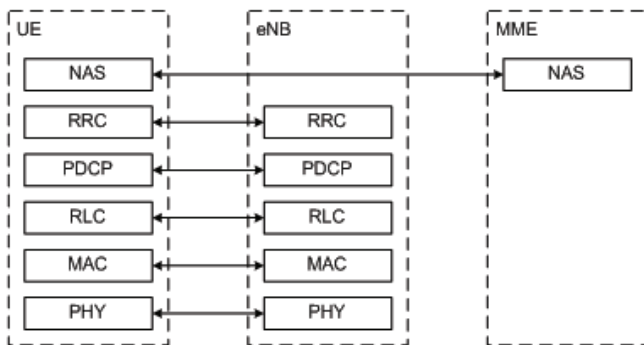

Figure 2: Control plane protocol stack

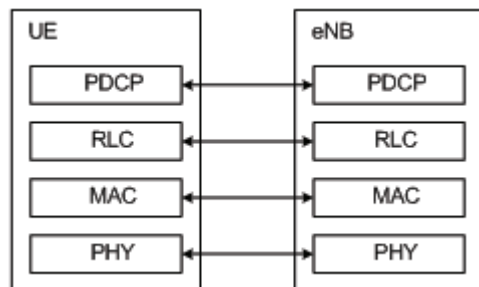

Figure 3: User plane protocol stack

In this section, we describe the functions of the different protocol layers and their location in the LTE architecture. Figures 2 and 3 show the control plane and the user plane protocol stacks, respectively [4]. In the control-plane, the NAS protocol, which runs between the MME and the UE, is used for control-purposes such as network attach, authentication, setting up of bearers, and mobility management. All NAS messages are ciphered and integrity protected by the MME and UE. The RRC layer in the eNB makes handover decisions based on neighbor cell measurements sent by the UE, pages for the UEs over the air, broadcasts system information, controls UE measurement reporting such as the periodicity of Channel Quality Information (CQI) reports and allocates cell-level temporary identifiers to active UEs. It also executes transfer of UE context from the source eNB to the target eNB during handover, and does integrity protection of RRC messages. The RRC layer is responsible for the setting up and maintenance of radio bearers.

In the user-plane, the PDCP layer is responsible for compressing/decompressing the headers of user plane IP packets using Robust Header Compression (ROHC) to enable efficient use of air interface bandwidth. This layer also performs ciphering of both user plane and control plane data. Because the NAS messages are carried in RRC, they are effectively double ciphered and integrity protected, once at the MME and again at the eNB.

The RLC layer is used to format and transport traffic between the UE and the eNB. RLC provides three different reliability modes for data transport- Acknowledged Mode (AM), Unacknowledged Mode (UM), or Transparent Mode (TM). The UM mode is suitable for transport of Real Time (RT) services because such services are delay sensitive and cannot wait for re-transmissions. The AM mode, on the other hand, is appropriate for non-RT (NRT) services such as file downloads. The TM mode is used when the PDU sizes are known a priori such as for broadcasting system information. The RLC layer also provides in-sequence delivery of Service Data Units (SDUs) to the upper layers and eliminates duplicate SDUs from being delivered to the upper layers. It may also segment the SDUs depending on the radio conditions.

Furthermore, there are two levels of re-transmissions for providing reliability, namely, the Hybrid Automatic Repeat reQuest (HARQ) at the MAC layer and outer ARQ at the RLC layer. The outer ARQ is required to handle residual errors that are not corrected by HARQ that is kept simple by the use of a single bit error-feedback mechanism. An N-process stop-and-wait HARQ is employed that has asynchronous re-transmissions in the DL and synchronous re-transmissions in the UL. Synchronous HARQ means that the re-transmissions of HARQ blocks occur at pre-defined periodic intervals. Hence, no explicit signaling is required to indicate to the receiver the retransmission schedule. Asynchronous HARQ offers the flexibility of scheduling re-transmissions based on air interface conditions. Figures 4 and 5 show the structure of layer 2 for DL and UL, respectively. The PDCP, RLC and MAC layers together constitute layer 2.

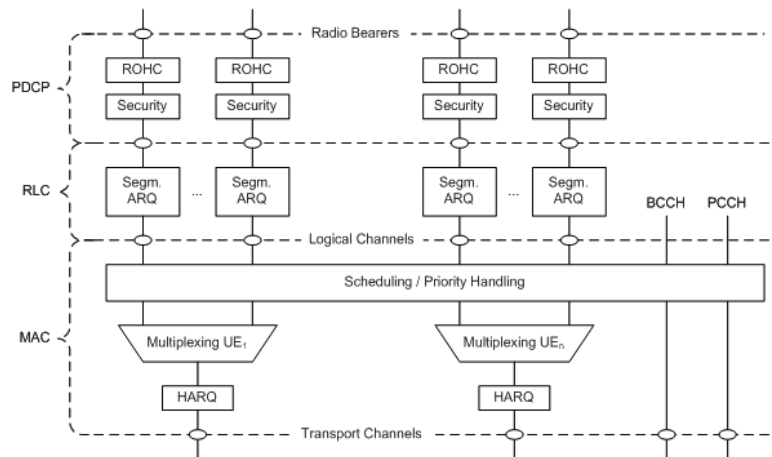

Figure 4: Layer 2 structure for DL

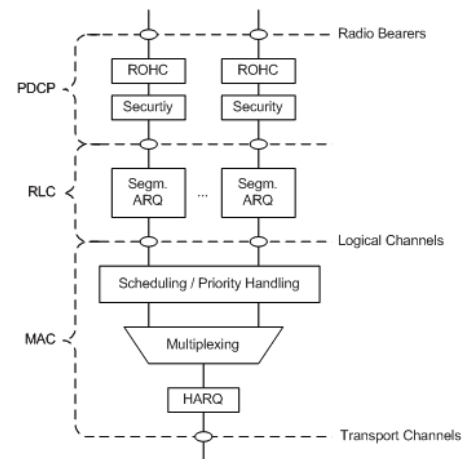

Figure 5: Layer 2 structure for UL

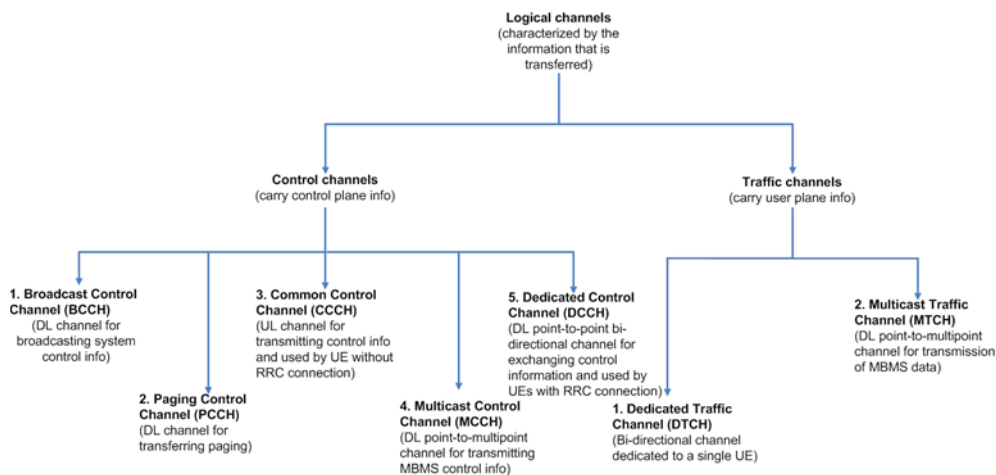

Figure 6: Logical channels in LTE

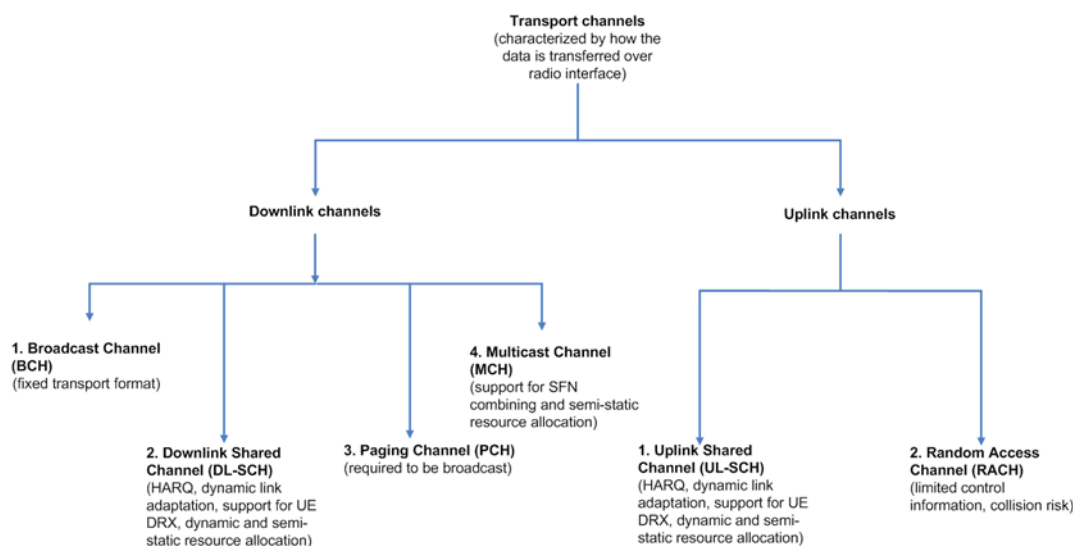

Figure 7: Transport channels in LTE

In LTE, there is significant effort to simplify the number and mappings of logical and transport channels. The different logical and transport channels in LTE are illustrated in Figures 6 and 7, respectively. The transport channels are distinguished by the characteristics (e.g. adaptive modulation and coding) with which the data are transmitted over the radio interface. The MAC layer performs the mapping between the logical channels and transport channels, schedules the different UEs and their services in both UL and DL depending on their relative priorities, and selects the most appropriate transport format. The logical channels are characterized by the information carried by them. The mapping of the logical channels to the transport channels is shown in Figure 8 [4]. The mappings shown in dotted lines are still being studied by 3GPP.

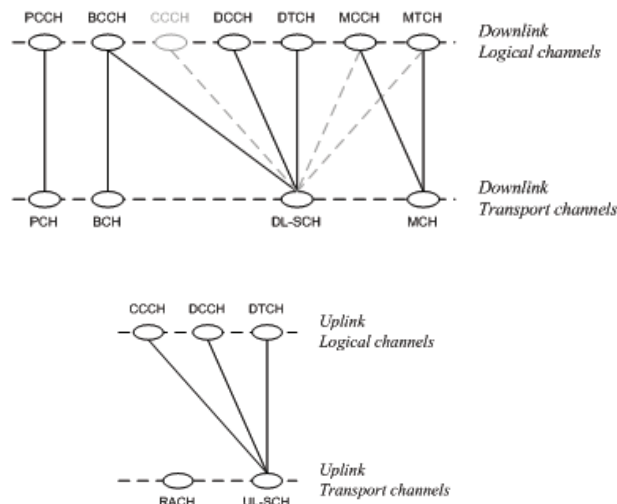

Figure 8: Logical to transport channel mapping [4]

The physical layer at the eNB is responsible for protecting data against channel errors using adaptive modulation and coding (AMC) schemes based on channel conditions. It also maintains frequency and time synchronization and performs RF processing including modulation and demodulation. In addition, it processes measurement reports from the UE such as CQI and provides indications to the upper layers. The minimum unit of scheduling is a time-frequency block corresponding to one sub-frame (1ms) and 12 sub-carriers. The scheduling is not done at a sub-carrier granularity in order to limit the control signaling. QPSK, 16QAM and 64QAM will be the DL and UL modulation schemes in E-UTRA. For UL, 64-QAM is optional at the UE.

Multiple antennas at the UE are supported with the 2 receive and 1 transmit antenna configuration being mandatory. MIMO (multiple input multiple output) is also supported at the eNB with two transmit antennas being the baseline configuration. Orthogonal Frequency Division Multiple Access (OFDMA) with a sub-carrier spacing of 15 kHz and Single Carrier Frequency Division Multiple Access (SC-FDMA) have been chosen as the transmission schemes for the DL and UL, respectively. Each radio frame is 10ms long containing 10 sub-frames with each sub-frame capable of carrying 14 OFDM symbols. For more details on these access schemes, refer to [4].

MOBILITY MANAGEMENT

Mobility management can be classified based on the radio technologies of the source and the target cells, and the mobility-state of the UE. From a mobility perspective, the UE can be in one of three states, LTE_DETACHED, LTE_IDLE, and LTE_ACTIVE as shown in Figure 7. LTE_DETACHED state is typically a transitory state in which the UE is powered-on but is in the process of searching and registering with the network. In the LTE_ACTIVE state, the UE is registered with the network and has an RRC connection with the eNB. In LTE_ACTIVE state, the network knows the cell to which the UE belongs and can transmit/receive data from the UE. The LTE_IDLE state is a power-conservation state for the UE, where typically the UE is not transmitting or receiving packets. In LTE_IDLE state, no context about the UE is stored in the eNB. In this state, the location of the UE is only known at the MME and only at the granularity of a tracking area (TA) that consists of multiple eNBs. The MME knows the TA in which the UE last registered and paging is necessary to locate the UE to a cell.

Idle Mode Mobility

In idle mode, the UE is in power-conservation mode and does not inform the network of each cell change. The network knows the location of the UE to the granularity of a few cells, called the Tracking Area (TA). When there is a UE-terminated call, the UE is paged in its last reported TA. Extensive discussions occurred in 3GPP on the preferred tracking area mechanism. Static non-overlapping track-

ing areas were used in earlier technologies, such as, GSM. However, there are newer techniques that avoid ping-pong effects, distribute the TA update load more evenly across cells and reduce the aggregate TA update load. Some of the candidate mechanisms that were discussed include overlapping TAs, multiple TAs and distance-based TA schemes. It has been agreed in 3GPP that a UE can be assigned multiple TAs that are assumed to be non-overlapping. It has also been agreed in 3GPP that TAs for LTE and for pre-LTE RATs will be separate i.e., an eNB and a UMTS Node-B will belong to separate TAs to simplify the network's handling of mobility of the UE when UE crosses 3GPP RAT boundaries.

Service Providers are likely to deploy LTE in a phased manner and pre-existing 3GPP technologies, such as, HSDPA, UMTS, EDGE and GPRS, are likely to remain for some time to come.

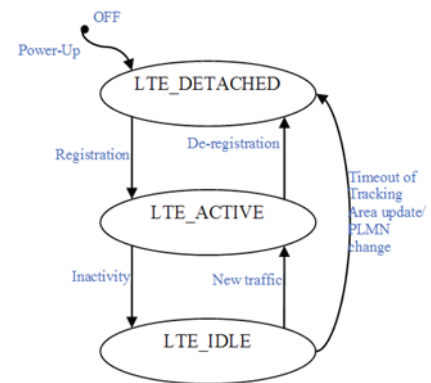

Figure 9: Mobility states of the UE in LTE.

There will be seams across between these technologies and 3GPP has devised ways to minimize the network signaling when a UE, capable of transmitting/receiving in multiple RATs, moves across these technology boundaries in idle mode. The objective is to keep the UE camped in the idle state of the different technologies, for e.g., LTE_IDLE in LTE and PMM_IDLE in UMTS/GPRS and also not to perform TA updates (LTE) or Routing Area (RA) updates (UTRAN/GERAN) as the UE moves between these technologies. To achieve this, the UE is assigned to both a TA and a RA. From then on, as long as the UE is moving among cells (possibly of different 3GPP technologies) that broadcast one of these equivalent TA or RA identities, the UE does not send a TA or RA update. When new traffic arrives for the UE, the UE is paged in both the technologies and depending on the technology in which the UE responds, data is forwarded through that RAT.

Such a tight co-ordination of being able to page in multiple technologies at the same time will not be possible with other RATs standardized by other standards bodies, such as, 3GPP2 and IEEE. Therefore, mobility between LTE and a non-3GPP technology would involve signaling the network of the technology change.

Connected Mode Mobility

In LTE_ACTIVE, when a UE moves between two LTE cells, “backward” handover or predictive handover is carried out. In this type of handover, the source cell, based on measurement reports from the UE, determines the target cell and queries the target cell if it has enough resources to accommodate the UE. The target cell also prepares radio resources before the source cell commands the UE to handover to the target cell.

In LTE, data buffering in the DL occurs at the eNB because the RLC protocol terminates at the eNB. Therefore, mechanisms to avoid data loss during inter-eNB handovers is all the more necessary when compared to the UMTS architecture where data buffering occurs at the centralized Radio Network Controller (RNC) and inter-RNC handovers are less frequent. Two mechanisms were proposed to minimize data loss during handover: Buffer forwarding and bi-casting. In buffer forwarding, once the handover decision is taken, the source eNB forwards buffered data for the UE to the target eNB. In bi-casting, the SGW bi-casts/multi-casts packets to a set of eNBs (including the serving eNB), which are candidates for being the next serving eNB. The bi-casting solution requires significantly higher backhaul bandwidth, and may still not be able to avoid data loss altogether. Moreover, the determination of when to start bi-casting is an important issue to address in the bi-casting solution. If bi-casting starts too early, there will be a significant increase in the backhaul bandwidth requirement. If bi-casting starts too late, it will result in packet loss. Therefore, the decision in 3GPP is that buffer forwarding would be the mechanism to avoid packet loss for intra-LTE handovers. The source eNB may decide whether or not to forward traffic depending on the type of traffic, e.g. perform data forwarding for NRT traffic and no data forwarding for RT traffic

The issue of whether a full RLC context transfer should happen, or if RLC can be reset for each handover has been debated. The majority opinion is that RLC should be reset during handovers, because of the complexity involved in RLC context transfer. If RLC is being reset, then partially transmitted RLC SDUs would have to be retransmitted to the UE resulting in inefficient use of air interface resources. Assuming that RLC will get reset for each handover, another issue to consider is whether only unacknowledged SDUs or all buffer contents starting from the first unacknowledged SDU would get transferred to the target eNB. 3GPP has decided that only unacknowledged DL PDCP SDUs would be transferred to the target eNB during handover. Note that this means that ciphering and header compression are always performed by that eNB that transmits the packets over-the-air.

PDCP sequence numbers are continued at the target eNB, which helps the UE to reorder packets to ensure in-order delivery of packets to the higher layers. Buffer and context transfer is expected to happen directly between eNBs through a new interface, called the X2 interface, without involving the SGW. One open question is whether or not to perform ROHC context transfer, when a UE is handed over from one eNB to another. There will be an improvement in radio efficiency with ROHC context transfer, but at the cost of increased complexity. Because ROHC is terminated at the eNBs in LTE, the frequency of ROHC reset will be larger than in the case of UMTS, where the PDCP protocol is terminated at the RNC.

For active mode handovers between LTE and other 3GPP technologies, it has been decided that there will be a user plane interface between the Serving GPRS Support Node (SGSN) and SGW. GTP-U will be used over this interface. Even though this type of handover will be less likely than intra-LTE handovers, 3GPP has discussed ways of minimizing packet losses for this type of handover as well and has decided in favor of a buffer forwarding scheme either directly from the eNB to RNC or indirectly through the SGW and SGSN.

For handover between LTE and other non-3GPP technologies, PMIPv6 and client MIPv4 FA mode will be used over the S2a interface while PMIPv6 will be employed over the S2b interface. DS-MIPv6 is the preferred protocol over S2c interface. The mobility schemes for handoffs between 3GPP and non-3GPP technologies do not assume that resources are prepared in the target technology before the UE performs a handover. However, proposals are being discussed to enable seamless mobility through prepared handover support.

Proxy Mobile IPv6 (PMIPv6), Mobile IPv4 Foreign Agent (MIPv4 FA) mode, and Dual-Stack Mobile IPv6 (DS-MIPv6)

EVOLVED MULTICAST BROADCAST MULTIMEDIA SERVICES (E-MBMS)

There will be support for MBMS right from the first version of LTE specifications. However, specifications for E-MBMS are in early stages. Two important scenarios have been identified for E-MBMS: One is single-cell broadcast, and the second is MBMS Single Frequency Network (MBSFN). MBSFN is a new feature that is being introduced in the LTE specification. MBSFN is envisaged for delivering services such as Mobile TV using the LTE infrastructure, and is expected to be a competitor to DVB-H-based TV broadcast. In MBSFN, the transmission happens from a time-synchronized set of eNBs using the same resource block. This enables over-the-air combining, thus improving the Signal-to-Interference plus Noise-Ratio (SINR) significantly compared to non-SFN operation. The Cyclic Prefix (CP) used for MBSFN is slightly longer, and this enables the UE to combine transmissions from different eNBs, thus somewhat negating some of the advantages of SFN operation. There will be six symbols in a slot of 0.5ms for MBSFN operation versus seven symbols in a slot of 0.5ms for non-SFN operation.

The overall user-plane architecture for MBSFN operation is shown in Figure 10. 3GPP has defined a SYNC protocol between the E-MBMS gateway and the eNBs to ensure that the same content is sent over-the-air from all the eNBs. As shown in the figure, eBM-SC is the source of the MBMS traffic, and the E-MBMS gateway is responsible for distributing the traffic to the different eNBs of the MBSFN area. IP multicast may be used for distributing the traffic from the E-MBMS gateway to the different eNBs. 3GPP has defined a control plane entity, known as the MBMS Coordination Entity (MCE) that ensures that the same resource block is allocated for a given service across all the eNBs of a given MBSFN area. It is the task of the MCE to ensure that the RLC/MAC layers at the eNBs are appropriately configured for MBSFN operation. 3GPP has currently assumed that header compression for MBMS services will be performed by the E-MBMS gateway.

Both single-cell MBMS and MBSFN will typically use point-to-multipoint mode of transmission. Therefore, UE feedback, such as ACK/NACK and CQI cannot be used as one could for the point-to-point case. However, aggregate statistical CQI and ACK/NACK information can still be used for link adaptation and retransmissions. Such techniques are currently being evaluated in 3GPP.

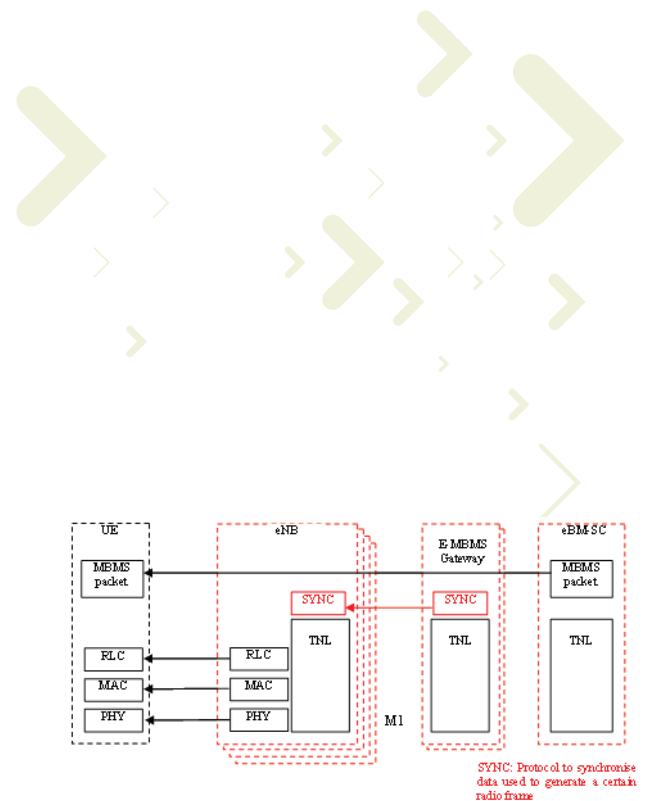

Figure 10: The overall U-plane architecture of the MBMS content synchronization [4]

MOTOROLA'S VIEW ON CERTAIN LTE DESIGN CHOICES

Motorola has been very active in the development of LTE standards and has been pushing for an architecture in which all the radio-specific functions are at the eNB; cellular specific control functionality is contained in control-plane nodes and CN user-plane nodes can be based on generic IP routers. Such architecture will result in lower capital (CAPEX) and operational (OPEX) expenditure for service providers.

The topics on which Motorola has made significant contributions on include:

- Flat RAN architecture
- Termination of RLC and PDCP protocol layers in the eNB
- Distributed radio resource management using direct eNB to eNB interaction
- Control-plane and user-plane separation resulting in the split between MME and serving gateway
- Use of IETF mobility protocols, specifically (proxy) Mobile IP, for mobility on the different interfaces
- Enabling SGW sharing between service providers
- Mobility solutions in active mode, including context transfer at RLC/PDCP layers, location of packet reordering function etc.
- Efficient TA concepts for idle mode mobility
- MBMS and SFN operation.

Motorola's position on the LTE architecture has been motivated by maximizing reuse of components and network elements across different technologies. Our position has been driven by the desire to reuse generic routers and IETF-based mobility protocols and network elements, such as, Home Agent (HA) and Foreign Agent (FA), as much as possible. Such re-use is expected to significantly reduce the CAPEX for service providers. Towards this end, Motorola has been influential in placing the RLC, PDCP and RRC protocols at the eNB. A key issue that has been decided as per Motorola's preference is the placement of user-plane encryption and header compression functionality at the eNB. Motorola has also been actively supporting mobility between 3GPP and non-3GPP networks, such as, WiMAX to enable seamless mobility of dual-mode devices across these technologies.

We have also helped eliminate a centralized server for inter-cell RRM arguing that it can be performed in a distributed fashion at the eNBs by showing that a centralized server would require frequent measurement reports from the UE. When RRM is distributed, eNBs may report their load information to neighboring cells based on events such as the load of the cell reaching 90%. This load information may be used by neighboring eNBs to decide whether handover to this particular eNB should be allowed.

On the control plane/user plane separation, we have been instrumental in securing the separation of the MME and the SGW. This will allow for independent scaling of the MME based on the number of sessions, and that of the SGW based on the volume of traffic. We can also optimize the placement of each of these entities in the network if they are separate and enable one-to-many relationship between MME and serving gateway.

On the issue of DL user plane context transfer between eNBs during intra-LTE handover, we preferred to perform full RLC context transfer. Not doing full RLC context transfer would mean transferring either entire RLC SDUs or PDCP SDUs, which would result in wastage of air interface bandwidth, if already acknowledged RLC PDUs are retransmitted from the target eNB. In a typical implementation of RLC, acknowledgments are not sent for every received PDU. Instead, the sender polls the receiver to obtain STATUS PDUs that contain the acknowledgments. Therefore, the number of SDUs that are unnecessarily retransmitted from the target eNB depends on the time of handover and the handover rate. Our analysis indicates that in the worst case, where the handover occurs just before receiving the STATUS PDU, 175 PDCP SDUs need to be unnecessarily retransmitted from the target eNB assuming a 1500 byte SDU size, 10ms round trip time (RTT), average air interface data rate of 10Mbps and a poll period of 200ms. We also observed that longer poll periods and higher UE speeds (and consequently higher handover rate) result in a larger fraction of time being spent on retransmission of SDUs from the target eNB. 3GPP has chosen to perform PDCP SDU level context transfer during handovers based on the simplicity of the solution. However, our preference that selective SDU forwarding is carried out, instead of cumulative SDU forwarding has been agreed by 3GPP. Cumulative SDU forwarding would mean that all SDUs from the first unacknowledged SDU are retransmitted to the UE from the target eNB, resulting in further wastage of air interface bandwidth.

Consistent with our other positions on efficient use of air interface bandwidth, we believe that ROHC context transfer would also be useful. However, there will be increased complexity due to ROHC context transfer. Currently, we are performing cost-benefit comparison to evaluate if the increased complexity of ROHC context transfer is justified by the resulting efficiency. Complete RLC context transfer, selective SDU forwarding, and ROHC context transfer result in user experience benefit by effectively reducing the handover latency by starting to transmit only unacknowledged packets at the highest compression efficiency from the target eNB.

For reducing idle-mode signaling for idle mode mobility between LTE and 2G/3G systems such as UMTS/HSPA, we provided analysis for comparing the required inter-technology updates for a scheme where the UE remains camped in the last used RAT unless there is a clear need to switch to a different technology i.e., only if there is an incoming call and the new RAT is the preferred technology, or if the UE moves to a region where there is no coverage of the last used RAT (Scheme 2) compared to the scheme where an inter-technology update is sent by the UE at every technology boundary crossing (Scheme 1). The analysis showed that rate of inter-technology update is lower in Scheme 2 compared to Scheme 1, especially when the speeds of the UEs are higher. This is shown in Figure 11 where λ is the call activity rate, α is the fraction of LTE coverage in the entire area and η is the average area of one LTE coverage pocket. The analysis assumes umbrella coverage of 2G/3G with circular pockets of LTE coverage. We also observed that when there are more E-UTRA pockets i.e., when η is small for a fixed α , it is more important to take measures to reduce inter-technology updates.

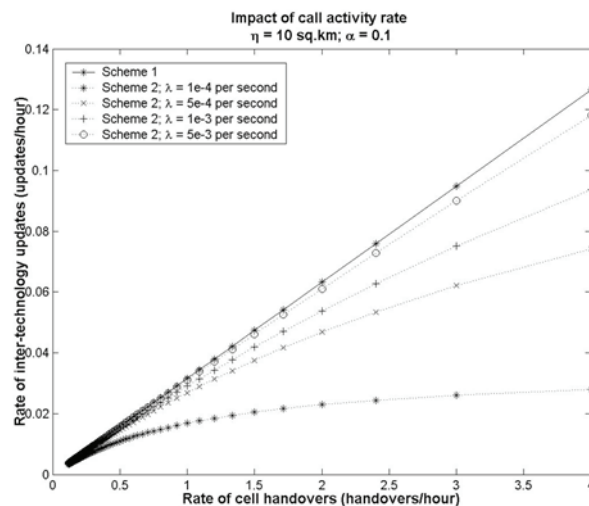

Figure 11: Impact of call activity rate on inter-technology updates

For MBSFN operation, Motorola has been favoring simplifying the scheduling and resource allocation problems by imposing the restriction that SFN areas should be non-overlapping. We have presented simulation results that show that the amount of resources saved by allowing overlapping SFNs is quite small. Figure 12 shows the percentage resource over-provisioning required for accommodating overlapping SFN areas, as a function of the fraction of cells in which any given service needs to be transmitted. This over-provisioning requirement is seen to be quite excessive. In addition, there is increased complexity of ensuring that these services obtain identical allocation across all the cells in which that service is being transmitted.

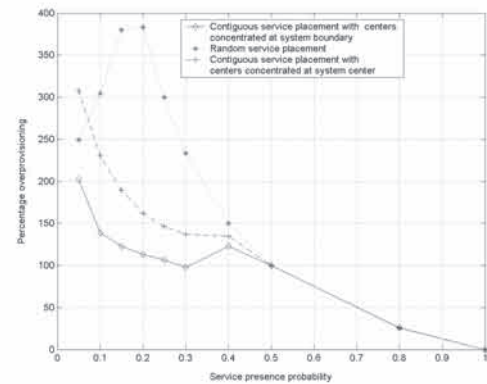

Figure 12: Amount of over-provisioning due to overlapping SFN areas

CONCLUSIONS

In this paper, we described the system architecture and performance objectives of the next generation access-network technology being developed by 3GPP.

We also discussed how mobility is handled in the new system. Motorola's role in this enhancement of 3GPP LTE technology was also explained.

With the envisaged throughput and latency targets and emphasis on simplicity, spectrum flexibility, added capacity and lower cost per bit, LTE is destined to provide greatly improved user experience, delivery of new revenue generating exciting mobile services and will remain a strong competitor to other wireless technologies in the next decade for both developed and emerging markets.

Motorola is leveraging its extensive expertise in mobile broadband innovation, including OFDM technologies (wi4 WiMAX), cellular networking (EVDOa, HSxPA), IMS ecosystem, collapsed IP architecture, standards development and implementation, comprehensive services to deliver best-in-class LTE solutions.

For more information on LTE, please talk to your Motorola representative.

REFERENCES

- [1]. 3GPP TR 25.913. Requirements for Evolved UTRA (E-UTRA) and Evolved UTRAN (E-UTRAN). Available at <http://www.3gpp.org>.
- [2]. 3GPP TS 23.401. GPRS enhancements on EUTRAN access. Available at <http://www.3gpp.org>.
- [3]. 3GPP TS 23.402. Architecture enhancements for non-3GPP accesses. Available at <http://www.3gpp.org>.
- [4]. 3GPP TS 36.300, EUTRA and EUTRAN overall description, Stage 2. Available at <http://www.3gpp.org>
- [5]. C. Perkins. IP Mobility Support for IPv4. RFC 3344, August 2002. Available at <http://www.ietf.org/rfc/rfc3344.txt?number=3344>.
- [6]. S. Gundavelli et. al. Proxy Mobile IPv6. IETF draft, April 2007. Available at <http://www.ietf.org/internet-drafts/drafts-ietf-netlmm-proxymip6-00.txt>.
- [7]. H. Soliman. Mobile IPv6 support for dual stack hosts and routers (DSMIPv6). Available at <http://tools.ietf.org/html/draft-ietf-mip6-nemo-v4traversal-04>.

Appendix A: LTE Reference Points

S1-MME Reference point for the control plane protocol between EUTRAN and MME. The protocol over this reference point is eRANAP and it uses Stream Control Transmission Protocol (SCTP) as the transport protocol

S1-U Reference point between EUTRAN and SGW for the per-bearer user plane tunneling and inter-eNB path switching during handover. The transport protocol over this interface is GPRS Tunneling Protocol-User plane (GTP-U)

S2a It provides the user plane with related control and mobility support between trusted non-3GPP IP access and the Gateway. S2a is based on Proxy Mobile IP. To enable access via trusted non-3GPP IP accesses that do not support PMIP, S2a also supports Client Mobile IPv4 FA mode

S2b It provides the user plane with related control and mobility support between evolved Packet Data Gateway (ePDG) and the PDN GW. It is based on Proxy Mobile IP

S2c It provides the user plane with related control and mobility support between UE and the PDN GW. This reference point is implemented over trusted and/or untrusted non-3GPP Access and/or 3GPP access. This protocol is based on Client Mobile IP co-located mode

S3 It is the interface between SGSN and MME and it enables user and bearer information exchange for inter 3GPP access network mobility in idle and/or active state. It is based on Gn reference point as defined between SGSNs

S4 It provides the user plane with related control and mobility support between SGSN and the SGW and is based on Gn reference point as defined between SGSN and GGSN

S5 It provides user plane tunneling and tunnel management between SGW and PDN GW. It is used for SGW relocation due to UE mobility and if the SGW needs to connect to a non-collocated PDN GW for the required PDN connectivity. Two variants of this interface are being standardized depending on the protocol used, namely, GTP and the IETF based Proxy Mobile IP solution [3]

S6a It enables transfer of subscription and authentication data for authenticating/authorizing user access to the evolved system (AAA interface) between MME and HSS

S7 It provides transfer of (QoS) policy and charging rules from Policy and Charging Rules Function (PCRF) to Policy and Charging Enforcement Function (PCEF) in the PDN GW. This interface is based on the Gx interface

S10 Reference point between MMEs for MME relocation and MME to MME information transfer

S11 Reference point between MME and SGW

SGi It is the reference point between the PDN GW and the packet data network. Packet data network may be an operator-external public or private packet data network or an intra-operator packet data network, e.g. for provision of IMS services. This reference point corresponds to Gi for 2G/3G accesses

Rx+ The Rx reference point resides between the Application Function and the PCRF in the 3GPP TS 23.203

Wn* This is the reference point between the Untrusted Non-3GPP IP Access and the ePDG. Traffic on this interface for a UE initiated tunnel has to be forced towards ePDG.



MOTOROLA

Motorola, Inc. www.motorola.com

The information presented herein is to the best of our knowledge true and accurate. No warranty or guarantee expressed or implied is made regarding the capacity, performance or suitability of any product. MOTOROLA and the Stylized M Logo are registered in the U.S. Patent and Trademark Office. All other product or service names are the property of their respective owners. © Motorola, Inc. 2007