

Rohde & Schwarz Products: FSQ, FSQ-K100, FSQ-K101, SMU200A, SMU-K55, SMU-K255, SMATE200A, SMATE-K55, SMATE-K255, SMJ100A, SMJ-K55, SMJ-K255, WinIQSIM2, AFQ100A, AFQ-K255, AMU200A, AMU-K55, AMU-K255

UMTS Long Term Evolution (LTE) Technology Introduction

Application Note 1MA111

Even with the introduction of HSDPA and HSUPA, evolution of UMTS has not reached its end. To ensure the competitiveness of UMTS for the next 10 years and beyond, UMTS Long Term Evolution (LTE) is being specified in 3GPP release 8. LTE, which is also known as Evolved UTRA and Evolved UTRAN, provides new physical layer concepts and protocol architecture for UMTS. This application note introduces LTE technology and testing aspects.



Contents

1	Introduction.....	3
2	Requirements for UMTS Long Term Evolution	4
3	LTE Downlink Transmission Scheme.....	5
	OFDMA.....	5
	OFDMA parametrization.....	6
	Downlink Data Transmission.....	8
	Downlink Reference Signal Structure and Cell Search	8
	Downlink Physical Layer Procedures	10
4	LTE Uplink Transmission Scheme	11
	SC-FDMA.....	11
	SC-FDMA Parametrization.....	12
	Uplink Reference Signal Structure	13
	Uplink Physical Layer Procedures	13
5	LTE MIMO Concepts.....	15
	Downlink MIMO.....	15
	Uplink MIMO	17
6	LTE Protocol Architecture.....	17
	System Architecture Evolution (SAE).....	17
	E-UTRAN	18
	Layer 2 structure	20
	Transport channels	21
	Logical channels	21
7	LTE MBMS Concepts.....	22
8	LTE Testing.....	23
	LTE RF testing	23
	LTE Layer 1 and Protocol Test.....	27
9	Abbreviations.....	27
10	Additional Information	30
11	References.....	30
12	Ordering Information	30

The following abbreviations are used in this application note for R&S test equipment:

- The Vector Signal Generator R&S® SMU200A is referred to as the SMU200A.
- The Vector Signal Generator R&S® SMATE200A is referred to as the SMATE200A.
- The Vector Signal Generator R&S® SMJ100A is referred to as the SMJ100A.
- SMU200A, SMATE200A, and SMJ100A in general is referred to as the SMx.
- The IQ Modulation Generation R&S® AFQ100A is referred to as the AFQ100A.
- The Baseband Signal Generator and Fading Simulator R&S® AMU200A is referred to as the AMU200A.
- The Signal Analyzer R&S® FSQ is referred to as FSQ.

1 Introduction

Currently, UMTS networks worldwide are being upgraded to High Speed Downlink Packet Access (HSDPA) in order to increase data rate and capacity for downlink packet data. In the next step, High Speed Uplink Packet Access (HSUPA) will boost uplink performance in UMTS networks. While HSDPA was introduced as a 3GPP release 5 feature, HSUPA is an important feature of 3GPP release 6. The combination of HSDPA and HSUPA is often referred to as HSPA.

However, even with the introduction of HSPA, evolution of UMTS has not reached its end. **HSPA+** will bring significant enhancements in 3GPP release 7. Objective is to enhance performance of HSPA based radio networks in terms of spectrum efficiency, peak data rate and latency, and exploit the full potential of WCDMA based 5 MHz operation. Important features of HSPA+ are downlink MIMO (Multiple Input Multiple Output), higher order modulation for uplink and downlink, improvements of layer 2 protocols, and continuous packet connectivity.

In order to ensure the competitiveness of UMTS for the next 10 years and beyond, concepts for **UMTS Long Term Evolution (LTE)** have been investigated. Objective is a high-data-rate, low-latency and packet-optimized radio access technology. Therefore, a study item was launched in 3GPP release 7 on E-UTRA (Evolved UMTS Terrestrial Radio Access) and E-UTRAN (Evolved UMTS Terrestrial Radio Access Network). LTE/E-UTRA will then form part of 3GPP release 8 core specifications.

This application note focuses on LTE/E-UTRA technology. In the following, the terms LTE or E-UTRA are used interchangeably.

In the context of the LTE study item, 3GPP work first focused on the definition of requirements, e.g. targets for data rate, capacity, spectrum efficiency, and latency. Also commercial aspects like costs for installing and operating the network were considered. Based on these requirements, technical concepts for the air interface transmission schemes and protocols were studied. Notably, LTE uses new multiple access schemes on the air interface: OFDMA (Orthogonal Frequency Division Multiple Access) in downlink and SC-FDMA (Single Carrier Frequency Division Multiple Access) in uplink. Furthermore, MIMO antenna schemes form an essential part of LTE. In an attempt to simplify protocol architecture, LTE brings some major changes to the existing UMTS protocol concepts. Impact on the overall network architecture including the core network is being investigated in the context of 3GPP System Architecture Evolution (SAE).

This application note gives an introduction to LTE technology.

Chapter 2 outlines requirements for LTE.

Chapter 3 describes the downlink transmission scheme for LTE.

Chapter 4 describes the uplink transmission scheme for LTE.

Chapter 5 outlines LTE MIMO concepts.

Chapter 6 focuses on LTE protocol architecture.

Chapter 7 introduces LTE MBMS (Multimedia Broadcast Multicast Service) concepts.

Chapter 8 explains test requirements for LTE.

Chapters 9-12 provide additional information including literature references.

2 Requirements for UMTS Long Term Evolution

LTE is focusing on optimum support of Packet Switched (PS) Services. Main requirements for the design of an LTE system have been captured in 3GPP TR 25.913 [1] and can be summarized as follows:

- **Data Rate:** Peak data rates target 100 Mbps (downlink) and 50 Mbps (uplink) for 20 MHz spectrum allocation, assuming 2 receive antennas and 1 transmit antenna at the terminal.
- **Throughput:** Target for downlink average user throughput per MHz is 3-4 times better than release 6. Target for uplink average user throughput per MHz is 2-3 times better than release 6.
- **Spectrum Efficiency:** Downlink target is 3-4 times better than release 6. Uplink target is 2-3 times better than release 6.
- **Latency:** The one-way transit time between a packet being available at the IP layer in either the UE or radio access network and the availability of this packet at IP layer in the radio access network/UE shall be less than 5 ms. Also C-plane latency shall be reduced, e.g. to allow fast transition times of less than 100 ms from camped state to active state.
- **Bandwidth:** Scaleable bandwidths of 5, 10, 15, 20 MHz shall be supported. Also bandwidths smaller than 5 MHz shall be supported for more flexibility.
- **Interworking:** Interworking with existing UTRAN/GERAN systems and non-3GPP systems shall be ensured. Multimode terminals shall support handover to and from UTRAN and GERAN as well as inter-RAT measurements. Interruption time for handover between E-UTRAN and UTRAN/GERAN shall be less than 300 ms for real time services and less than 500 ms for non real time services.
- **Multimedia Broadcast Multicast Services (MBMS):** MBMS shall be further enhanced and is then referred to as E-MBMS.
- **Costs:** Reduced CAPEX and OPEX including backhaul shall be achieved. Cost effective migration from release 6 UTRA radio interface and architecture shall be possible. Reasonable system and terminal complexity, cost and power consumption shall be ensured. All the interfaces specified shall be open for multi-vendor equipment interoperability.
- **Mobility:** The system should be optimized for low mobile speed (0-15 km/h), but higher mobile speeds shall be supported as well including high speed train environment as special case.
- **Spectrum allocation:** Operation in paired (Frequency Division Duplex / FDD mode) and unpaired spectrum (Time Division Duplex / TDD mode) is possible.
- **Co-existence:** Co-existence in the same geographical area and co-location with GERAN/UTRAN shall be ensured. Also, co-existence between operators in adjacent bands as well as cross-border co-existence is a requirement.
- **Quality of Service:** End-to-end Quality of Service (QoS) shall be supported. VoIP should be supported with at least as good radio and

backhaul efficiency and latency as voice traffic over the UMTS circuit switched networks

- **Network synchronization:** Time synchronization of different network sites shall not be mandated.

3 LTE Downlink Transmission Scheme

OFDMA

The downlink transmission scheme for E-UTRA FDD and TDD modes is based on conventional OFDM. In an OFDM system, the available spectrum is divided into multiple carriers, called sub-carriers, which are orthogonal to each other. Each of these sub-carriers is independently modulated by a low rate data stream.

OFDM is used as well in WLAN, WiMAX and broadcast technologies like DVB. OFDM has several benefits including its robustness against multipath fading and its efficient receiver architecture.

Figure 1 shows a representation of an OFDM signal taken from [2]. In this figure, a signal with 5 MHz bandwidth is shown, but the principle is of course the same for the other E-UTRA bandwidths. Data symbols are independently modulated and transmitted over a high number of closely spaced orthogonal sub-carriers. In E-UTRA, downlink modulation schemes QPSK, 16QAM, and 64QAM are available.

In the time domain, a guard interval may be added to each symbol to combat inter-OFDM-symbol-interference due to channel delay spread. In E-UTRA, the guard interval is a **cyclic prefix** which is inserted prior to each OFDM symbol.

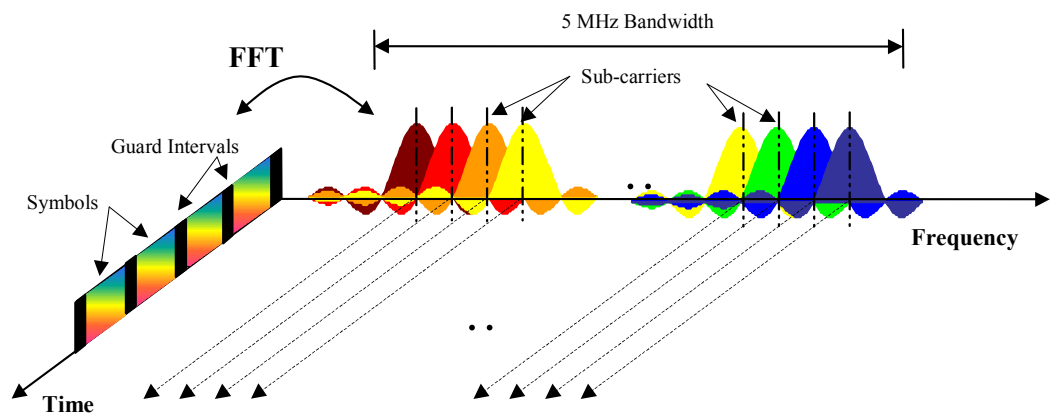

Figure 1 Frequency-Time Representation of an OFDM Signal

In practice, the OFDM signal can be generated using IFFT (Inverse Fast Fourier Transform) digital signal processing. The IFFT converts a number N of complex data symbols used as frequency domain bins into the time domain signal. Such an N -point IFFT is illustrated in Figure 2, where $a(mN+n)$ refers to the n^{th} sub-channel modulated data symbol, during the time period $mT_u < t \leq (m+1)T_u$.

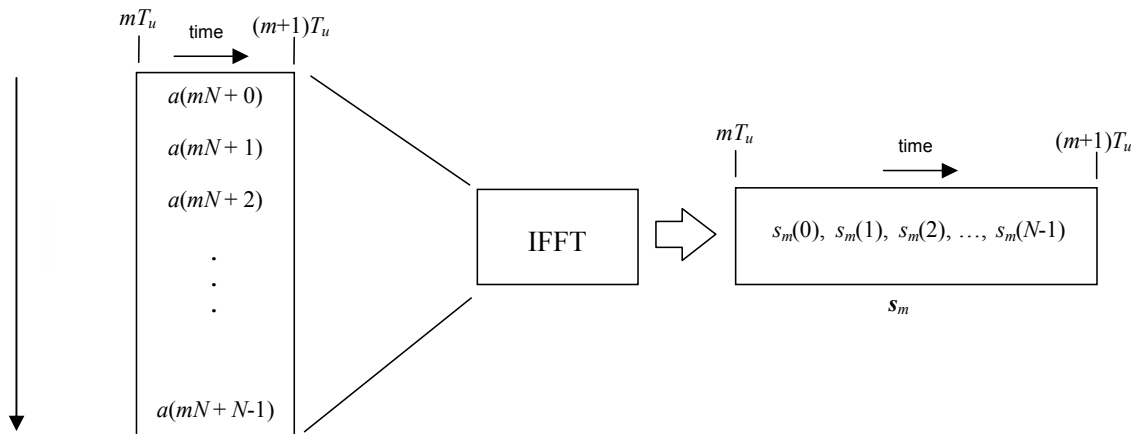

Figure 2 OFDM Useful Symbol Generation using an IFFT

The vector \mathbf{s}_m is defined as the useful OFDM symbol. It is the time superposition of the N narrowband modulated sub-carriers. Therefore, From a parallel stream of N sources of data, each one independently modulated, a waveform composed of N orthogonal sub-carriers is obtained, with each sub-carrier having the shape of a frequency *sinc* function (see Figure 1).

Figure 3 illustrates the mapping from a serial stream of QAM symbols to N parallel streams, used as frequency domain bins for the IFFT. The N -point time domain blocks obtained from the IFFT are then serialized to create a time domain signal. Not shown in Figure 3 is the process of cyclic prefix insertion.

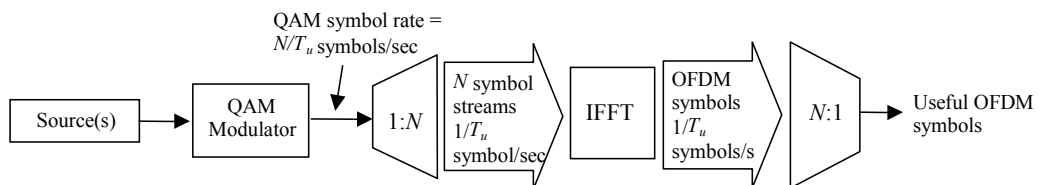

Figure 3 OFDM Signal Generation Chain

In contrast to an OFDM transmission scheme, **OFDMA** allows the access of multiple users on the available bandwidth. Each user is assigned a specific time-frequency resource. As a fundamental principle of E-UTRA, the data channels are shared channels, i.e. for each transmission time interval of 1 ms, a new scheduling decision is taken regarding which users are assigned to which time/frequency resources during this transmission time interval.

OFDMA parametrization

A **generic frame structure** is defined for both E-UTRA FDD and TDD modes. Additionally, an alternative frame structure is defined for the TDD mode only. The E-UTRA frame structures are defined in [3]. For the generic

frame structure, the 10 ms radio frame is divided into 20 equally sized slots of 0.5 ms. A sub-frame consists of two consecutive slots, so one radio frame contains 10 sub-frames. This is illustrated in Figure 4 (T_s is expressing the basic time unit corresponding to 30.72 MHz).

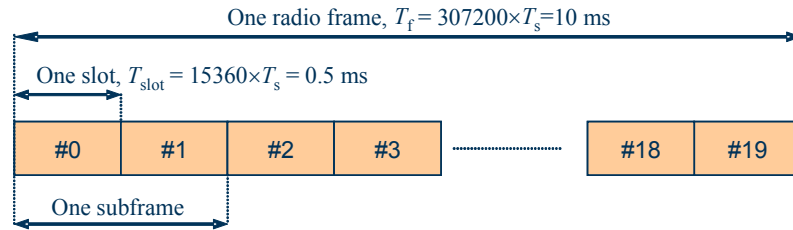

Figure 4 Generic frame structure in E-UTRA downlink

Figure 5 shows the structure of the downlink resource grid for the duration of one downlink slot. The available downlink bandwidth consists of N_{BW}^{DL} sub-carriers with a spacing of $\Delta f = 15$ kHz. In case of multi cell MBMS transmission (see chapter 7), a sub-carrier spacing of $\Delta f = 7.5$ kHz is also possible. N_{BW}^{DL} can vary in order to allow for scalable bandwidth operation up to 20 MHz. Initially, the bandwidths for LTE were explicitly defined within layer 1 specifications. Later on a bandwidth agnostic layer 1 was introduced, with N_{BW}^{DL} for the different bandwidths to be specified by 3GPP RAN4 to meet performance requirements, e.g. for out-of-band emission requirements and regulatory emission limits.

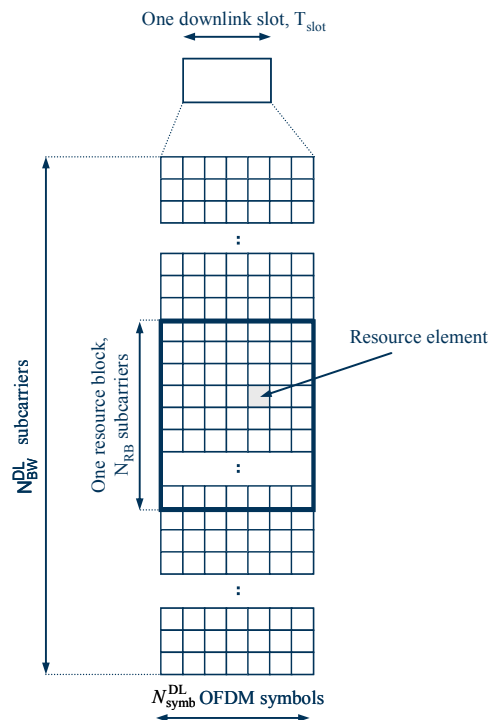

Figure 5 Downlink resource grid

One downlink slot consists of N_{symb}^{DL} OFDM symbols. To each symbol, a cyclic prefix (CP) is appended as guard time, compare Figure 1.

$N_{\text{symp}}^{\text{DL}}$ depends on the cyclic prefix length. The generic frame structure with normal cyclic prefix length contains $N_{\text{symp}}^{\text{DL}} = 7$ symbols. This translates into a cyclic prefix length of $T_{\text{CP}} \approx 5.2\mu\text{s}$ for the first symbol and $T_{\text{CP}} \approx 4.7\mu\text{s}$ for the remaining 6 symbols. Additionally, an extended cyclic prefix is defined in order to cover large cell scenarios with higher delay spread and MBMS transmission. The generic frame structure with extended cyclic prefix of $T_{\text{CP-E}} \approx 16.7\mu\text{s}$ contains $N_{\text{symp}}^{\text{DL}} = 6$ OFDM symbols (sub-carrier spacing 15 kHz). The generic frame structure with extended cyclic prefix of $T_{\text{CP-E}} \approx 33.3\mu\text{s}$ contains $N_{\text{symp}}^{\text{DL}} = 3$ symbols (sub-carrier spacing 7.5 kHz).

Table 1 gives an overview of the different parameters again for the generic frame structure.

Table 1 Parameters for downlink generic frame structure

Configuration	Number of symbols $N_{\text{symp}}^{\text{DL}}$	Cyclic Prefix length in samples	Cyclic Prefix length in μs
Normal cyclic prefix $\Delta f = 15$ kHz	7	160 for first symbol 144 for other symbols	5.2 μs for first symbol 4.7 μs for other symbols
Extended cyclic prefix $\Delta f = 15$ kHz	6	512	16.7 μs
Extended cyclic prefix $\Delta f = 7.5$ kHz	3	1024	33.3 μs

Downlink Data Transmission

Data is allocated to the UEs in terms of **resource blocks**. A physical resource block consists of 12 (24) consecutive sub-carriers in the frequency domain for the $\Delta f = 15$ kHz ($\Delta f = 7.5$ kHz) case. In the time domain, a physical resource block consists of $N_{\text{symp}}^{\text{DL}}$ consecutive OFDM symbols, see *Figure 5*.

$N_{\text{symp}}^{\text{DL}}$ is equal to the number of OFDM symbols in a slot. The resource block size is the same for all bandwidths, therefore the number of available physical resource blocks depends on the bandwidth.

Depending on the required data rate, each UE can be assigned one or more resource blocks in each transmission time interval of 1 ms. The scheduling decision is done in the base station (eNodeB).

The user data is carried on the Physical Downlink Shared Channel (**PDSCH**). Downlink control signaling on the Physical Downlink Control Channel (**PDCCH**) is used to convey the scheduling decisions to individual UEs. The PDCCH is located in the first OFDM symbols of a slot.

Downlink Reference Signal Structure and Cell Search

The downlink reference signal structure is important for cell search, channel estimation and neighbor cell monitoring. *Figure 6* shows the principle of the downlink reference signal structure for 1 antenna, 2 antenna, and 4 antenna transmission. Specific pre-defined resource elements in the time-frequency domain are carrying the reference signal sequence. Besides first reference symbols, there may be a need for second reference symbols. The different colors in *Figure 6* represent the sequences transmitted from up to 4 transmit antennas.

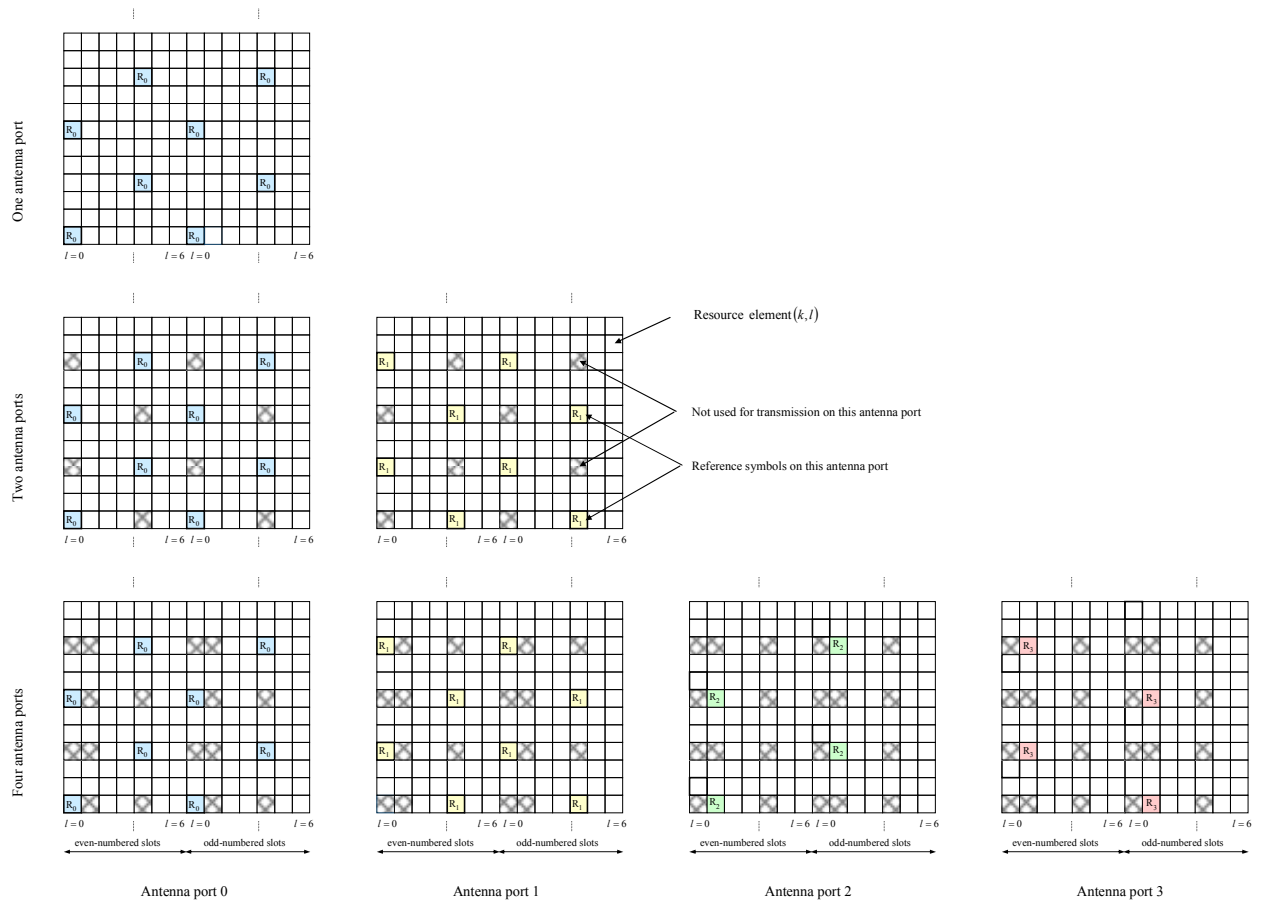

Figure 6 Downlink reference signal structure (normal cyclic prefix)

The reference signal sequence carries the cell identity. Each reference signal sequence is generated as a symbol-by-symbol product of an orthogonal sequence r^{OS} (3 of them existing) and a pseudo-random sequence r^{PRS} (170 of them existing). Each cell identity corresponds to a unique combination of one orthogonal sequence r^{OS} and one pseudo-random sequence r^{PRS} , allowing 510 different cell identities.

Frequency hopping can be applied to the downlink reference signals. The frequency hopping pattern has a period of one frame (10 ms).

During cell search, different types of information need to be identified by the handset: symbol and radio frame timing, frequency, cell identification, overall transmission bandwidth, antenna configuration, cyclic prefix length.

Besides the reference symbols, synchronization signals are therefore needed during cell search. E-UTRA uses a hierarchical cell search scheme similar to WCDMA. This means that the synchronization acquisition and the cell group identifier are obtained from different **SCH** signals. Thus, a primary synchronization signal (P-SCH) and a secondary synchronization signal (S-SCH) are defined with a pre-defined structure. They are transmitted on the 72 centre sub-carriers (around DC sub-carrier) within the same predefined slots (twice per 10 ms) on different resource elements, see Figure 7.

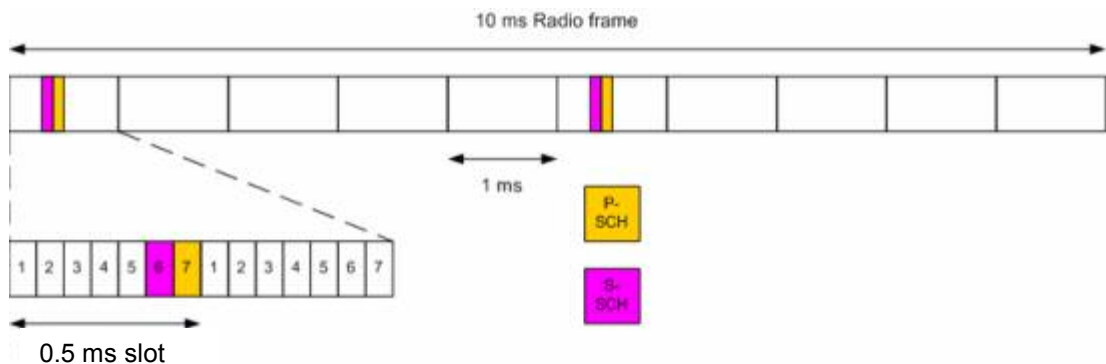

Figure 7 P-SCH and S-SCH structure

As additional help during cell search, a Common Control Physical Channel (**CCPCH**) is available which carries BCH type of information, e.g. system bandwidth. It is transmitted at pre-defined time instants on the 72 sub-carriers centered around DC sub-carrier.

In order to enable the UE to support this cell search concept, it was agreed to have a minimum UE bandwidth reception capability of 20 MHz.

Downlink Physical Layer Procedures

For E-UTRA, the following downlink physical layer procedures are especially important:

- **Cell search and synchronization:**

See above.

- **Scheduling:**

Scheduling is done in the base station (eNodeB). The downlink control channel PDCCH informs the users about their allocated time/frequency resources and the transmission formats to use. The scheduler evaluates different types of information, e.g. Quality of Service parameters, measurements from the UE, UE capabilities, buffer status.

- **Link Adaptation:**

Link adaptation is already known from HSDPA as Adaptive Modulation and Coding. Also in E-UTRA, modulation and coding for the shared data channel is not fix, but it is adapted according to radio link quality. For this purpose, the UE regularly reports Channel Quality Indications (CQI) to the eNodeB.

- **Hybrid ARQ (Automatic Repeat Request):**

Downlink Hybrid ARQ is also known from HSDPA. It is a retransmission protocol. The UE can request retransmissions of incorrectly received data packets.

4 LTE Uplink Transmission Scheme

SC-FDMA

During the study item phase of LTE, alternatives for the optimum uplink transmission scheme were investigated. While OFDMA is seen optimum to fulfil the LTE requirements in downlink, OFDMA properties are less favourable for the uplink. This is mainly due to weaker peak-to-average power ratio (PAPR) properties of an OFDMA signal, resulting in worse uplink coverage.

Thus, the LTE uplink transmission scheme for FDD and TDD mode is based on **SC-FDMA** (Single Carrier Frequency Division Multiple Access) with cyclic prefix. SC-FDMA signals have better PAPR properties compared to an OFDMA signal. This was one of the main reasons for selecting SC-FDMA as LTE uplink access scheme. The PAPR characteristics are important for cost-effective design of UE power amplifiers. Still, SC-FDMA signal processing has some similarities with OFDMA signal processing, so parametrization of downlink and uplink can be harmonized.

There are different possibilities how to generate an SC-FDMA signal. DFT-spread-OFDM (DFT-s-OFDM) has been selected for E-UTRA. The principle is illustrated in *Figure 8*.

For **DFT-s-OFDM**, a size-M DFT is first applied to a block of M modulation symbols. QPSK, 16QAM and 64 QAM are used as uplink E-UTRA modulation schemes, the latter being optional for the UE. The DFT transforms the modulation symbols into the frequency domain. The result is mapped onto the available sub-carriers. In E-UTRA uplink, only localized transmission on consecutive sub-carriers is allowed. An N point IFFT where $N > M$ is then performed as in OFDM, followed by addition of the cyclic prefix and parallel to serial conversion.

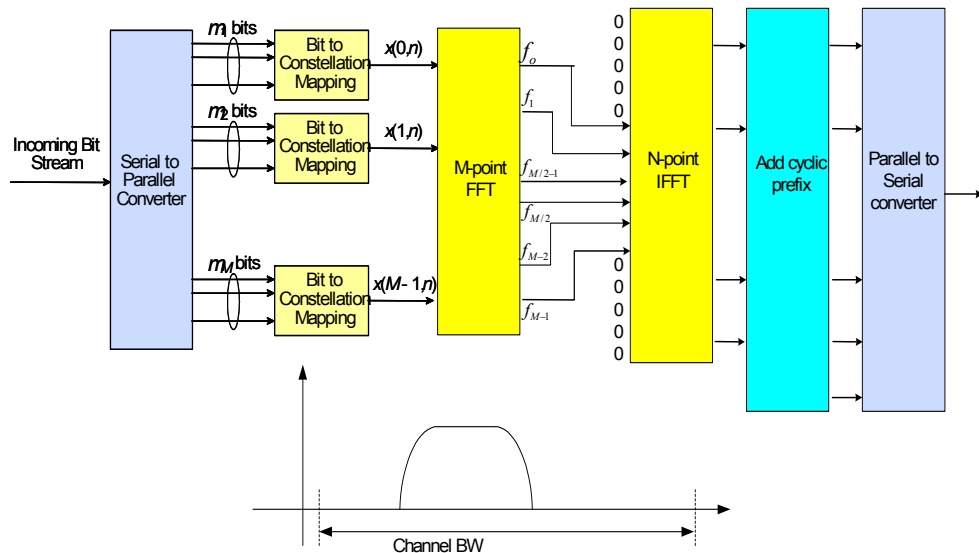

Figure 8 Block Diagram of DFT-s-OFDM (Localized transmission)

The DFT processing is therefore the fundamental difference between SC-FDMA and OFDMA signal generation. This is indicated by the term DFT-spread-OFDM. In an SC-FDMA signal, each sub-carrier used for transmission contains information of all transmitted modulation symbols,

since the input data stream has been spread by the DFT transform over the available sub-carriers. In contrast to this, each sub-carrier of an OFDMA signal only carries information related to specific modulation symbols.

SC-FDMA Parametrization

The E-UTRA uplink structure is similar to the downlink. An uplink radio frame consists of 20 slots of 0.5 ms each, and 1 subframe consists of 2 slots. The slot structure is shown in Figure 9.

Each slot carries $N_{\text{symb}}^{\text{UL}}$ SC-FDMA symbols, where $N_{\text{symb}}^{\text{UL}} = 7$ for the normal cyclic prefix and $N_{\text{symb}}^{\text{UL}} = 6$ for the extended cyclic prefix. SC-FDMA symbol number 3 (i.e. the 4th symbol in a slot) carries the reference signal for channel demodulation.

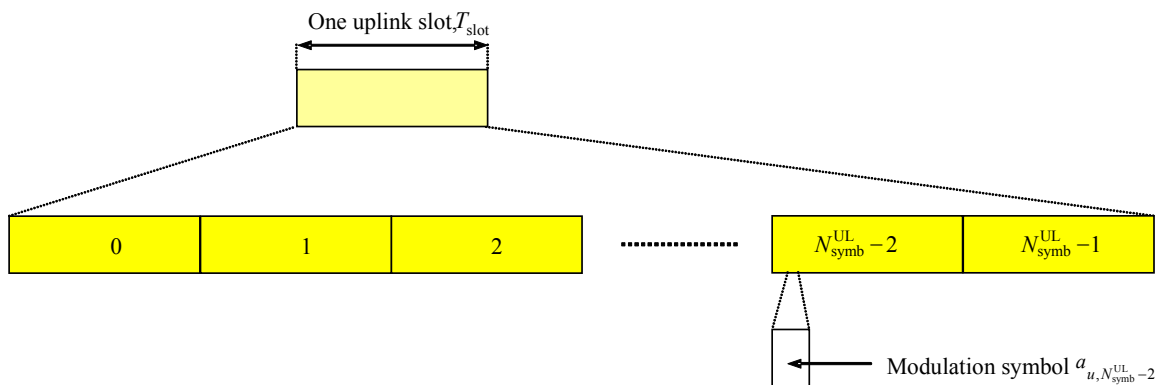

Figure 9 Uplink slot structure

Also for the uplink, a bandwidth agnostic layer 1 specification has been selected.

Table 2 shows the configuration parameters in an overview table.

Table 2 Parameters for uplink generic frame structure

Configuration	Number of symbols $N_{\text{symb}}^{\text{UL}}$	Cyclic Prefix length in samples	Cyclic Prefix length in μs
Normal cyclic prefix $\Delta f = 15 \text{ kHz}$	7	160 for first symbol 144 for other symbols	5.2 μs for first symbol 4.7 μs for other symbols
Extended cyclic prefix $\Delta f = 15 \text{ kHz}$	6	512	16.7 μs

Uplink Data Transmission

In uplink, data is allocated in multiples of one resource block. Uplink resource block size in the frequency domain is 12 sub-carriers, i.e. the same as in downlink. However, not all integer multiples are allowed in order to simplify the DFT design in uplink signal processing. Only factors 2,3, and 5 are allowed.

The uplink transmission time interval is 1 ms (same as downlink).

User data is carried on the Physical Uplink Shared Channel (**PUSCH**) that is determined by the transmission bandwidth N_{Tx} and the frequency hopping pattern k_0 .

The Physical Uplink Control Channel (**PUCCH**) carries uplink control information, e.g. CQI reports and ACK/NACK information related to data packets received in the downlink. The PUCCH is transmitted on a reserved frequency region in the uplink.

Uplink Reference Signal Structure

Uplink reference signals are used for two different purposes: on the one hand, they are used for channel estimation in the eNodeB receiver in order to demodulate control and data channels. On the other hand, the reference signals provide channel quality information as a basis for scheduling decisions in the base station. The latter purpose is also called channel sounding.

The uplink reference signals are based on CAZAC (Constant Amplitude Zero Auto-Correlation) sequences.

Uplink Physical Layer Procedures

For E-UTRA, the following uplink physical layer procedures are especially important:

- **Non-synchronized random access:**

The random access may be used to request initial access, as part of handover, when transiting from idle to connected, or to re-establish uplink synchronization. The structure is shown in *Figure 10*.

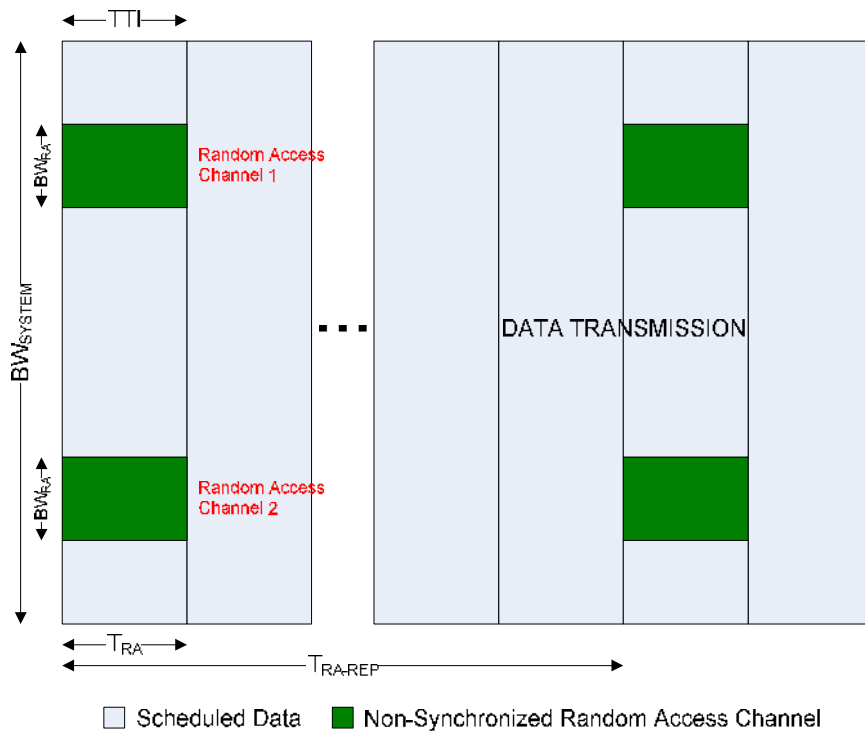

Figure 10 Random access structure, principle

Multiple random access channels may be defined in the frequency domain within one access period T_{RA} in order to provide a sufficient number of random access opportunities.

For the random access, a preamble is defined as shown in Figure 11. The preamble sequence occupies $T_{PRE} = 0.8$ ms and the cyclic prefix occupies $T_{CP} = 0.1$ ms within one subframe of 1 ms. During the guard time T_{GT} , nothing is transmitted. The preamble bandwidth is 1.08 MHz (72 sub-carriers). Higher layer signaling controls in which sub-frames the preamble transmission is allowed, and the location in the frequency domain. Per cell, there are 64 random access preambles. They are generated from Zadoff-Chu sequences.

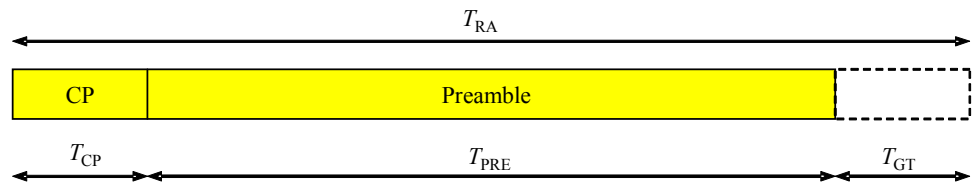

Figure 11 *Random access preamble*

The random access procedure uses open loop power control with power ramping similar to WCDMA. After sending the preamble on a selected random access channel, the UE waits for the random access response message. If no response is detected then another random access channel is selected and a preamble is sent again.

- **Uplink scheduling:**

Scheduling of uplink resources is done by eNodeB. The eNodeB assigns certain time/frequency resources to the UEs and informs UEs about transmission formats to use. Scheduling decisions affecting the uplink are communicated to the UEs via the PDCCH in the downlink. The scheduling decisions may be based on QoS parameters, UE buffer status, uplink channel quality measurements, UE capabilities, UE measurement gaps, etc.

- **Uplink link adaptation:**

As uplink link adaptation methods, transmission power control, adaptive modulation and channel coding rate, as well as adaptive transmission bandwidth can be used.

- **Uplink timing control:**

Uplink timing control is needed to time align the transmissions from different UEs with the receiver window of the eNodeB. The eNodeB sends the appropriate timing-control commands to the UEs in the downlink, commanding them to adapt their respective transmit timing.

- **Hybrid ARQ:**

Uplink Hybrid ARQ protocol is already known from HSUPA. The eNodeB has the capability to request retransmissions of incorrectly received data packets.

5 LTE MIMO Concepts

Multiple Input Multiple Output (MIMO) systems form an essential part of LTE in order to achieve the ambitious requirements for throughput and spectral efficiency. MIMO refers to the use of multiple antennas at transmitter and receiver side.

Downlink MIMO

For the LTE downlink, a 2x2 configuration for MIMO is assumed as baseline configuration, i.e. 2 transmit antennas at the base station and 2 receive antennas at the terminal side. Configurations with 4 antennas are also being considered.

Downlink MIMO modes

Different MIMO modes are envisaged. It has to be differentiated between spatial multiplexing and transmit diversity, and it depends on the channel condition which scheme to select.

Spatial Multiplexing

Spatial multiplexing allows to transmit different streams of data simultaneously on the same downlink resource block(s). These data streams can belong to one single user (single user MIMO / SU-MIMO) or to different users (multi user MIMO / MU-MIMO). While SU-MIMO increases the data rate of one user, MU-MIMO allows to increase the overall capacity. Spatial multiplexing is only possible if the mobile radio channel allows it. *Figure 12* shows the principle of spatial multiplexing, exploiting the spatial dimension of the radio channel which allows to transmit the different data streams simultaneously.

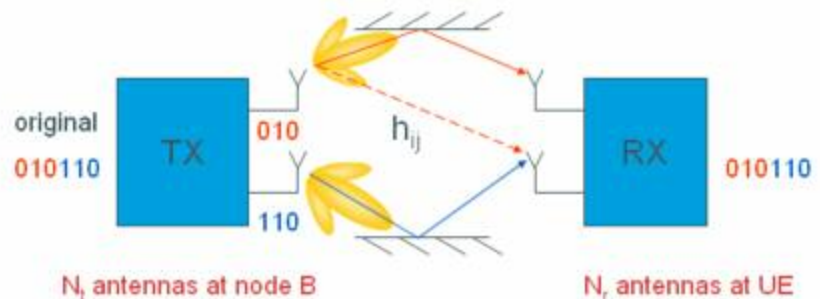

Figure 12 Spatial multiplexing

In *Figure 12*, each transmit antenna transmits a different data stream. Each receive antenna may receive the data streams from all transmit antennas. The channel (for a specific delay) can thus be described by the following channel matrix H :

$$H = \begin{matrix} & \xrightarrow{N_t} & & & \\ \begin{matrix} \uparrow \\ \vdots \\ \downarrow \end{matrix} & \begin{bmatrix} h_{11} & h_{12} & \dots & h_{1N_r} \\ h_{21} & h_{22} & \dots & h_{2N_r} \\ \vdots & \vdots & \ddots & \vdots \\ h_{N_t1} & h_{N_t2} & \dots & h_{N_tN_r} \end{bmatrix} & \begin{matrix} \leftarrow \\ \vdots \\ \rightarrow \end{matrix} & N_r & \\ & & & & \end{matrix}$$

In this general description, N_t is the number of transmit antennas, N_r is the number of receive antennas, resulting in a 2×2 matrix for the baseline LTE scenario. The coefficients h_{ij} of this matrix are called channel coefficients from transmit antenna j to receive antenna i , thus describing all possible paths between transmitter and receiver side.

The number of data streams that can be transmitted in parallel over the MIMO channel is given by $\min\{N_t, N_r\}$ and is limited by the rank of the matrix H . The transmission quality degrades significantly in case the singular values of matrix H are not sufficiently strong. This can happen in case the 2 antennas are not sufficiently de-correlated, for example in an environment with little scattering or when antennas are too closely spaced.

In LTE, up to 2 code words can be mapped onto different so-called layers. The number of layers for transmission is equal to the rank of the matrix H . There is a fixed mapping between code words to layers.

Precoding on transmitter side is used to support spatial multiplexing, see *Figure 13*. This is achieved by applying a precoding matrix \mathbf{W} to the signal before transmission.

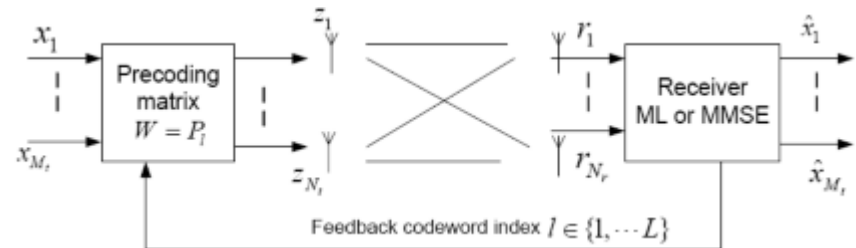

Figure 13 Precoding principle

The optimum precoding matrix \mathbf{W} is selected from a predefined “codebook” which is known at eNodeB and UE side. Unitary precoding is used, i.e. the precoding matrices are unitary: $\mathbf{W}^H \mathbf{W} = \mathbf{I}$. The UE estimates the radio channel and selects the optimum precoding matrix. The optimum precoding matrix is the one which offers maximum capacity. The UE provides feedback on the uplink control channel regarding the preferred precoding matrix (precoding vector as a special case). Ideally, this information is made available per resource block or at least group of resource blocks, since the optimum precoding matrix varies between resource blocks.

Figure 14 gives an overview of EUTRA downlink baseband signal generation including the above-mentioned steps relevant for MIMO transmission.

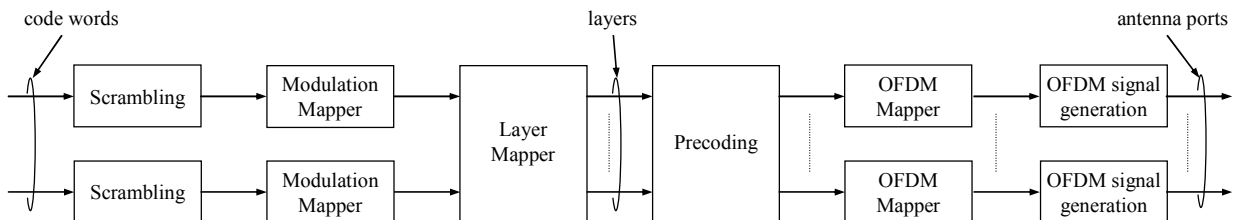

Figure 14 Overview of downlink baseband signal generation

Transmit Diversity

Instead of increasing data rate or capacity, MIMO can be used to exploit diversity. Transmit diversity schemes are already known from WCDMA release 99 and will also form part of LTE as one MIMO mode. In case the channel conditions do not allow spatial multiplexing, a transmit diversity scheme will be used instead, so switching between these two MIMO modes is possible depending on channel conditions. Transmit diversity is used when the selected number of streams (rank) is one.

Uplink MIMO

Uplink MIMO schemes for LTE will differ from downlink MIMO schemes to take into account terminal complexity issues. For the uplink, MU-MIMO can be used. Multiple user terminals may transmit simultaneously on the same resource block. This is also referred to as spatial domain multiple access (SDMA). The scheme requires only one transmit antenna at UE side which is a big advantage. The UEs sharing the same resource block have to apply mutually orthogonal pilot patterns.

To exploit the benefit of two or more transmit antennas but still keep the UE cost low, antenna subset selection can be used. In the beginning, this technique will be used, e.g. a UE will have two transmit antennas but only one transmit chain and amplifier. A switch will then choose the antenna that provides the best channel to the eNodeB.

6 LTE Protocol Architecture

System Architecture Evolution (SAE)

SAE is a study within 3GPP targeting at the evolution of the overall system architecture. Objective is "to develop a framework for an evolution or migration of the 3GPP system to a higher-data-rate, lower-latency, packet-optimized system that supports multiple radio access technologies. The focus of this work is on the PS domain with the assumption that voice services are supported in this domain". This study includes the vision of an all-IP network [5]. Clear requirement is the support of heterogeneous access networks in terms of mobility and service continuity. *Figure 15* gives an overview of the evolved system architecture.

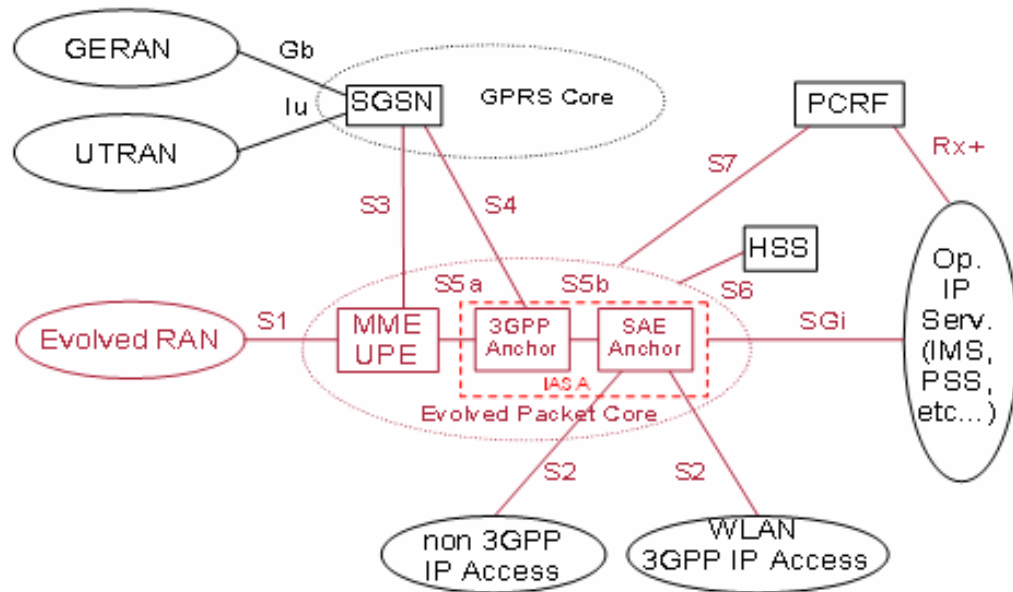

* Color coding: red indicates new functional element / interface

Figure 15 System architecture evolution

E-UTRAN

E-UTRAN stage 2 description can be found in [4]. The E-UTRAN consists of eNodeBs (eNBs), providing the E-UTRA user plane (PDCP/RLC/MAC/PHY) and control plane (RRC) protocol terminations towards the UE. The eNBs are interconnected with each other by means of the X2 interface. The eNBs are also connected by means of the S1 interface to the EPC (Evolved Packet Core), more specifically to the MME (Mobility Management Entity) and to the SAE Gateway. NAS protocols are terminated in MME.

The following figure illustrates the functional split between eNodeB (eNB) and Evolved Packet Core.

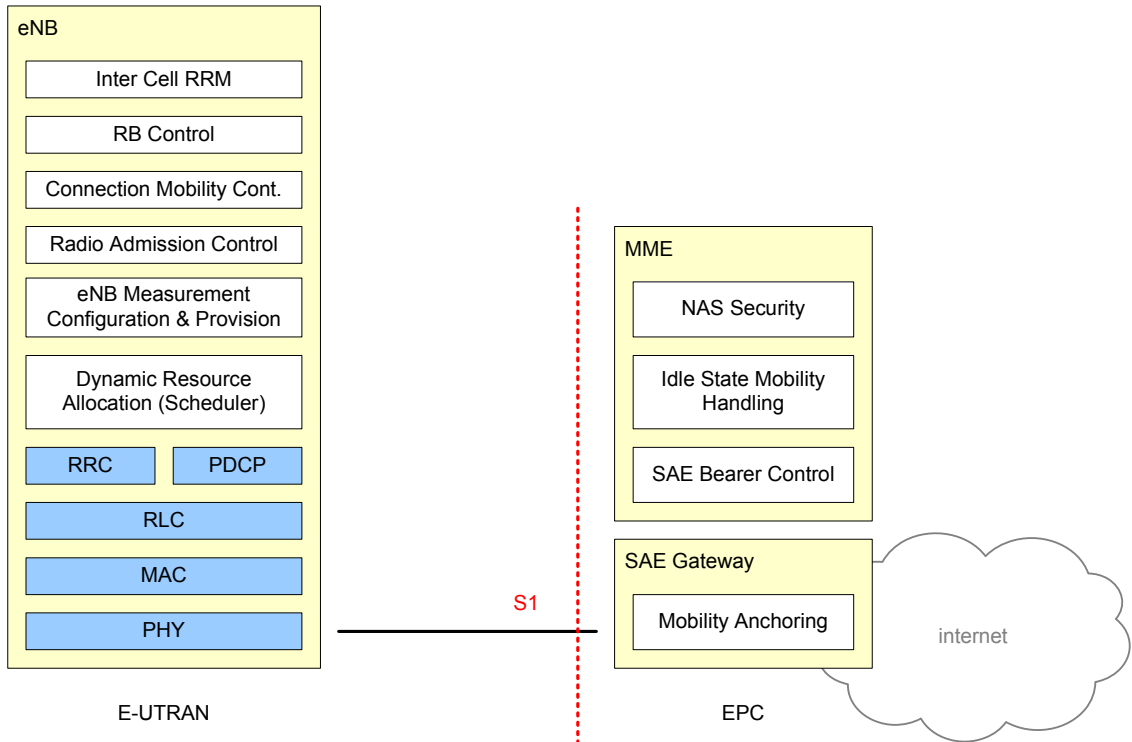

Figure 16 Functional split between E-UTRAN and Evolved Packet Core

The base station functionality has increased significantly in E-UTRAN, e.g. compared to WCDMA release 99. The base station hosts functions for radio bearer control, admission control, mobility control, uplink and downlink scheduling as well as measurement configuration.

User plane protocol stack is shown in Figure 17.

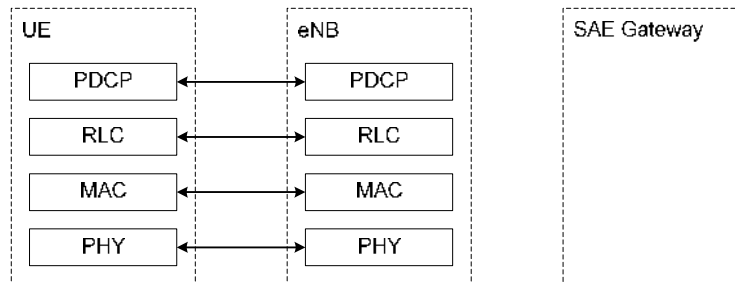

Figure 17 User plane protocol stack

Control plane protocol stack is shown in Figure 18.

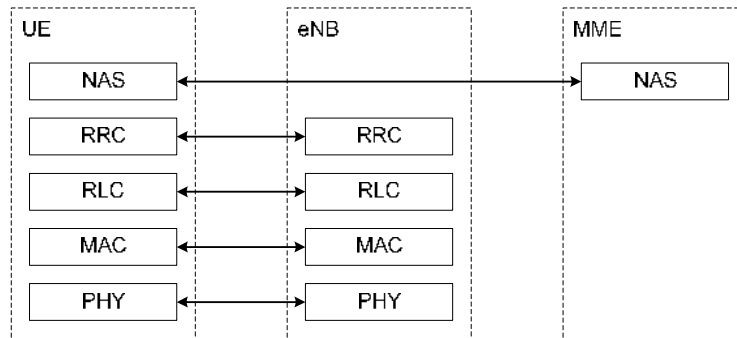

Figure 18 Control plane protocol stack

Layer 2 structure

Figure 19 and Figure 20 show the downlink and uplink structure of layer 2. The service access points between the physical layer and the MAC sublayer provide the transport channels. The service access points between the MAC sublayer and the RLC sublayer provide the logical channels. Radio bearers are defined on top of PDCP layer. Multiplexing of several logical channels on the same transport channel is possible. In both uplink and downlink, only one transport block is generated per transmission time interval in the non-MIMO case. E-UTRAN provides ARQ and HARQ functionalities. The ARQ functionality provides error correction by retransmissions in acknowledged mode at layer 2. The HARQ functionality ensures delivery between peer entities at layer 1. The HARQ is an N-channel stop-and-wait protocol with asynchronous downlink retransmissions and synchronous uplink retransmissions. ARQ retransmissions are based on RLC status reports and HARQ/ARQ interaction.

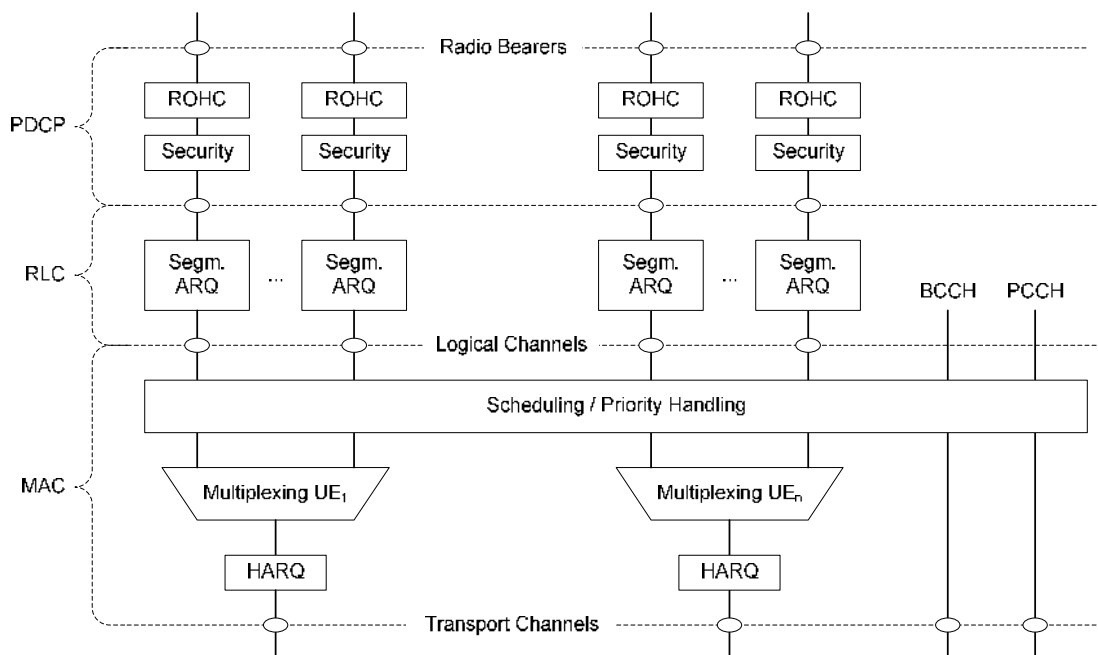

Figure 19 Downlink layer 2 structure

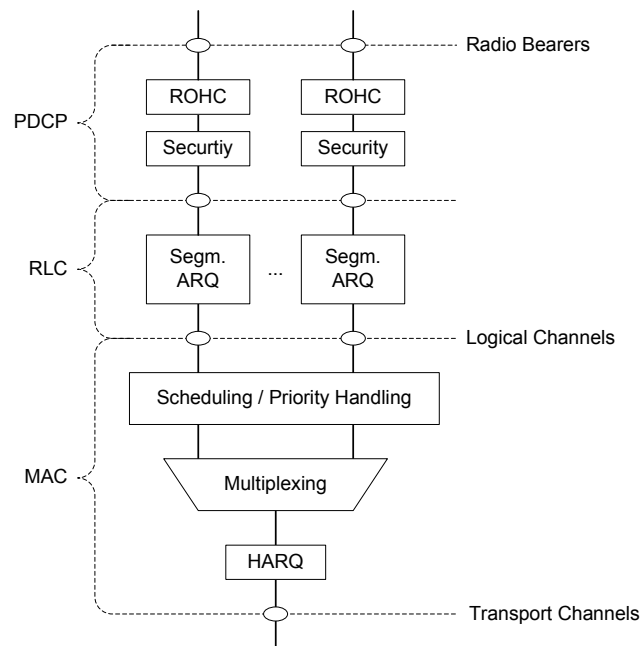

Figure 20 Uplink layer 2 structure

Transport channels

In order to reduce complexity of the LTE protocol architecture, the number of transport channels was reduced. This is mainly due to the focus on shared channel operation, i.e. no dedicated channels are used any more. Downlink transport channels are:

- Broadcast Channel (BCH)
- Downlink Shared Channel (DL-SCH)
- Paging Channel (PCH)
- Multicast Channel (MCH)

Uplink transport channels are:

- Uplink Shared Channel (UL-SCH)
- Random Access Channel (RACH)

Logical channels

Logical channels can be classified in control and traffic channels.

Control channels are:

- Broadcast Control Channel (BCCH)
- Paging Control Channel (PCCH)
- Common Control Channel (CCCH)
- Multicast Control Channel (MCCH)
- Dedicated Control Channel (DCCH)

Traffic channels are:

- Dedicated Traffic Channel (DTCH)

- Multicast Traffic Channel (MTCH)

Mapping between logical and transport channels in downlink and uplink is shown in the following figures.

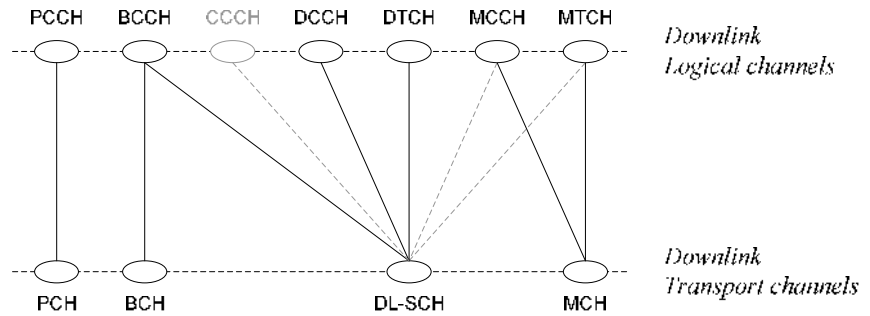

Figure 21 Mapping between downlink logical and transport channels

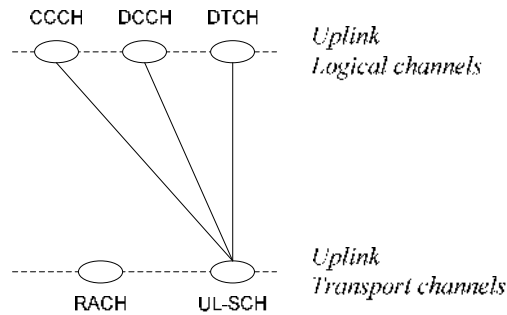

Figure 22 Mapping between uplink logical and transport channels

7 LTE MBMS Concepts

As shown in [1], support of MBMS (Multimedia Broadcast Multicast Services) is an essential requirement for LTE. The so-called E-MBMS will therefore be an integral part of LTE.

In LTE, MBMS transmissions may be performed as single-cell transmission or as multi-cell transmission. In case of multi-cell transmission the cells and content are synchronized to enable for the terminal to soft-combine the energy from multiple transmissions. The superimposed signal looks like multipath to the terminal. This concept is also known as Single Frequency Network (SFN). The E-UTRAN can configure which cells are part of an SFN for transmission of an MBMS service. The MBMS traffic can share the same carrier with the unicast traffic or be sent on a separate carrier. For MBMS traffic, an extended cyclic prefix is provided. In case of subframes carrying MBMS SFN data, specific reference signals are used.

MBMS data is carried on the MBMS traffic channel (MTCH) as logical channel.

8 LTE Testing

LTE RF testing

This section highlights aspects of testing base station and terminal transmitter and receiver parts and RF components for LTE.

First of all, LTE signal characteristics need to be investigated. While for LTE downlink, developers can leverage from OFDMA expertise gained with technologies like WiMAX and WLAN, this is not so straightforward for the uplink. SC-FDMA technology used in LTE uplink is not known from other standards yet. Thus, uplink signal characteristics need to be investigated with particular caution.

General settings

The following parameters primarily characterize the LTE signal:

- Frequency
- Bandwidth / number of resource blocks of the LTE signal
- Antenna configuration
- Reference signal sequence configuration
- Downlink synchronisation channel configuration
- Cyclic prefix length
- Allocation of user data and modulation schemes
- Configuration of L1/2 control channels

LTE signal generation

For generating an LTE signal, signal generators **SMU200A**, **SMJ100A** or **SMATE200A** are available. Software option SMx-K55 (*Digital Standard LTE/EUTRA*) provides LTE functionality on these signal generators. Alternatively, simulation software **WinIQSIM2** running on a PC can be used to generate waveforms for digitally modulated signals which can be uploaded on the above-mentioned signal generators. This requires software option SMx-K255. WinIQSIM2 is also available for the IQ modulation generator **AFQ100A** with software option AFQ-K255. The **AMU200A** baseband signal generator and fading simulator supports LTE with software option AMU-K55 or AMU-K255.

Figure 23 shows the OFDMA time plan used to illustrate the resource allocation within the LTE downlink signal configured by the user. In the example in *Figure 23*, a 0.5 ms slot of a 5 MHz LTE downlink signal is shown. The x-axis represents OFDM symbols, the y-axis represents resource blocks. In this example, all available resource blocks are allocated with user data. The reference symbols are located in the first and fifth OFDM symbol, and the L1/L2 control channel occupies the first two OFDM symbols. Note that these settings are configurable to create an LTE signal individually.

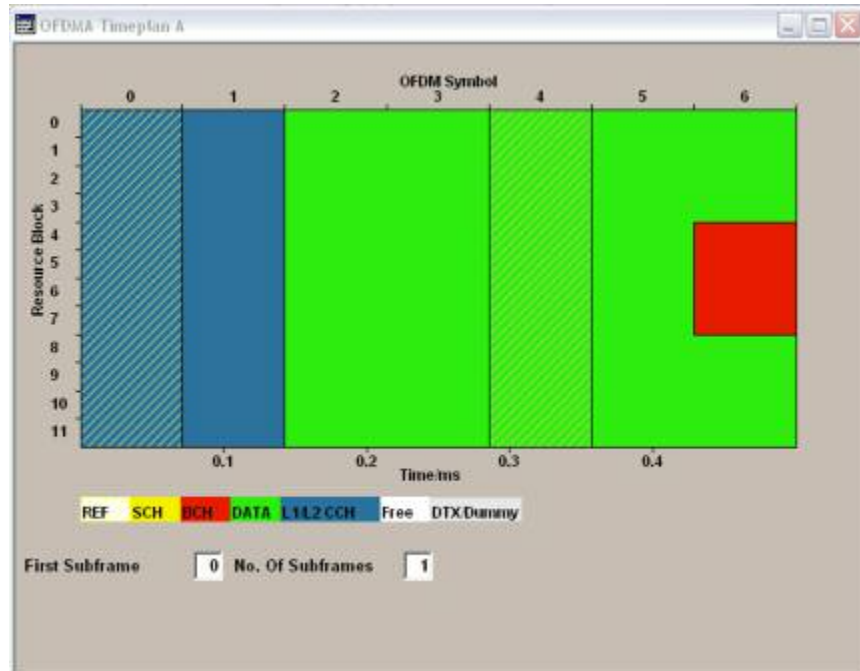

Figure 23 OFDMA time plan for LTE signal generation, 1 slot

Another example of the OFDMA time plan is shown in Figure 24. Here, an excerpt of 10 slots is shown, highlighting the repetition interval of the SCH. In this example, the allocation with user data varies over time, e.g. to simulate a specific scheduling scenario.

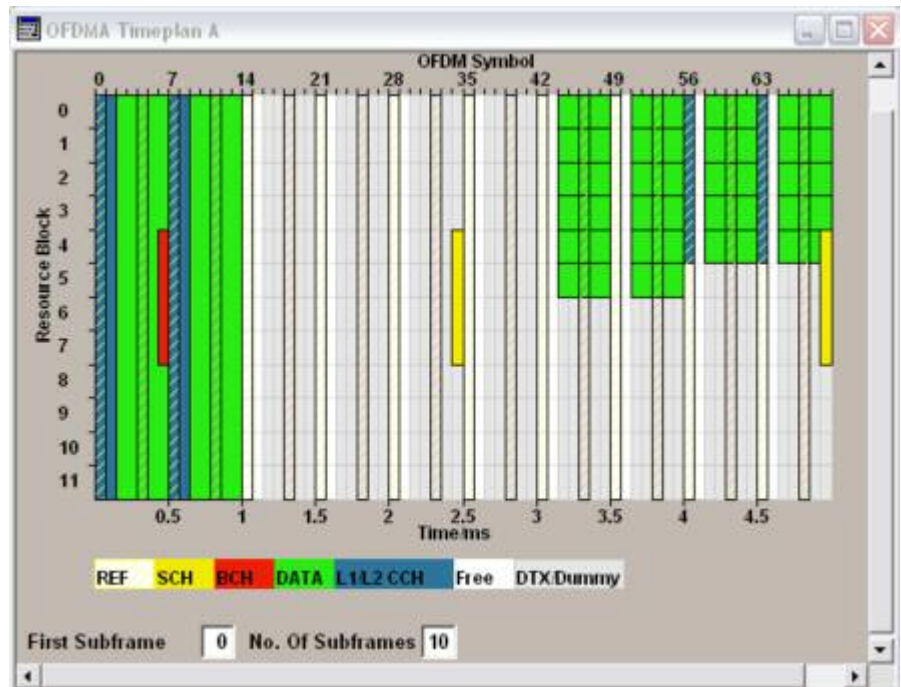

Figure 24 OFDMA time plan for LTE signal generation, 10 slots

LTE signal analysis

For analyzing the RF characteristics of an LTE signal, spectrum and signal analyzer **FSQ** can be used. Software options FSQ-K100 (*Application firmware 3GPP LTE/EUTRA downlink*) and FSQ-K101 (*Application firmware 3GPP LTE/EUTRA uplink*) are needed for LTE signal analysis.

Various measurement applications are offered: modulation quality, Error Vector Magnitude (EVM), constellation diagram, spectrum measurements, CCDF measurements, frequency error. For example, *Figure 25* shows the measurement of EVM versus carrier of an LTE downlink signal. Alternatively, EVM could be measured versus symbol. The upper part of *Figure 25* shows the capture buffer over the selected time interval of 10 ms.

EVM analysis is of special interest for LTE. Due to the higher order modulation schemes up to 64QAM, stringent EVM requirements for the transmitter side apply in order to prevent a decrease in throughput.



Figure 25 Measurement of EVM versus carrier

CCDF and crest factor are important measurements for power amplifier design. *Figure 26* shows the CCDF measurement of an LTE downlink signal.



Figure 26 CCDF measurement

As an example for spectrum measurements, *Figure 27* shows the flatness difference of an LTE downlink signal spectrum.

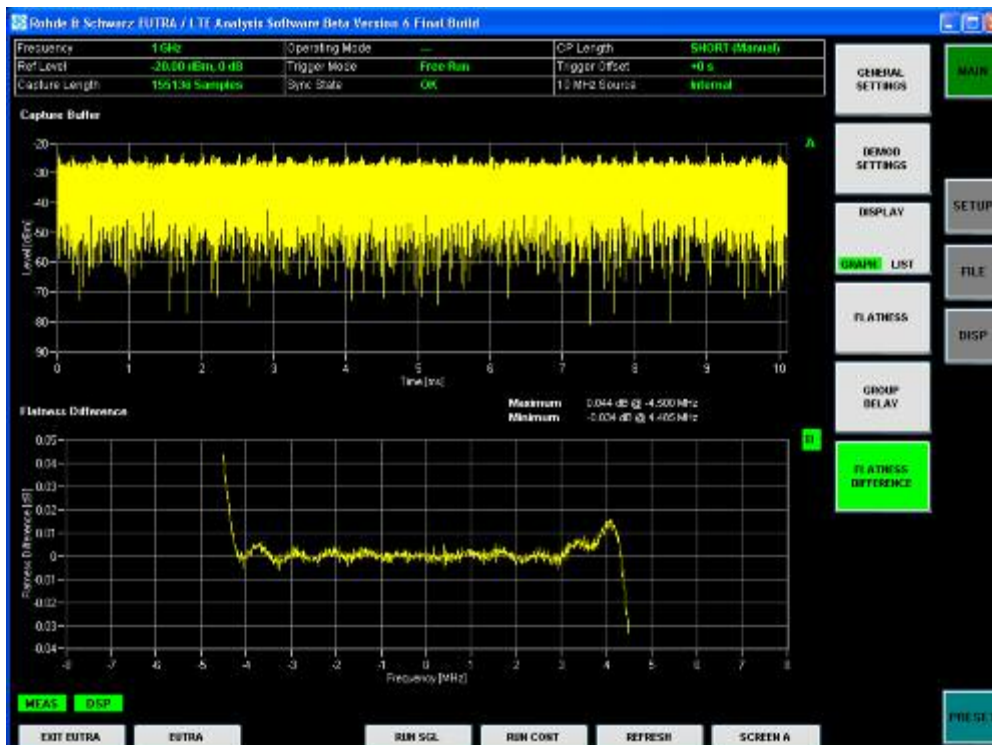

Figure 27 Measurement of flatness difference

LTE Layer 1 and Protocol Test

LTE layer 1 has significant functionality. This includes layer 1 procedures like cell search, Hybrid ARQ retransmission protocol, scheduling, link adaptation, uplink timing control and power control. Furthermore, these procedures have stringent timing requirements. Therefore thorough testing of layer 1 procedures is needed to guarantee LTE performance.

LTE protocol stack testing is needed to verify signaling functionality like call setup and release, call reconfigurations, state handling, and mobility. Interworking with 2G and 3G systems is a requirement for LTE and needs to be tested carefully. A special focus is put on verification of throughput requirements in order to make sure that the terminal protocol stack and applications are capable of handling high data rates. Flexible test scenarios with individual parametrization possibilities will be needed for R&D purposes already at a very early stage of LTE implementation.

9 Abbreviations

3GPP	3rd Generation Partnership Project
ACK	Acknowledgement
ACLR	Adjacent Channel Leakage Ratio
ARQ	Automatic Repeat Request
AS	Access Stratum
BCCH	Broadcast Control Channel
BCH	Broadcast Channel
CAZAC	Constant Amplitude Zero Auto-Correlation
CAPEX	Capital Expenditures
CCDF	Complementary Cumulative Density Function
CCPCH	Common Control Physical Channel
CP	Cyclic Prefix
C-plane	Control Plane
CQI	Channel Quality Indicator
CRC	Cyclic Redundancy Check
DCCH	Dedicated Control Channel
DFT	Discrete Fourier Transform
DL	Downlink
DL-SCH	Downlink Shared Channel
DRX	Discontinuous Reception
DTCH	Dedicated Traffic Channel
DTX	Discontinuous Transmission
DVB	Digital Video Broadcast
eNB	E-UTRAN NodeB
EPC	Evolved Packet Core

LTE/E-UTRA

E-UTRA	Evolved UMTS Terrestrial Radio Access
E-UTRAN	Evolved UMTS Terrestrial Radio Access Network
FDD	Frequency Division Duplex
FFT	Fast Fourier Transform
GERAN	GSM EDGE Radio Access Network
GSM	Global System for Mobile communication
HARQ	Hybrid Automatic Repeat Request
HSDPA	High Speed Downlink Packet Access
HSUPA	High Speed Uplink Packet Access
IFFT	Inverse Fast Fourier Transformation
IP	Internet Protocol
LTE	Long Term Evolution
MAC	Medium Access Control
MBMS	Multimedia Broadcast Multicast Service
MCCH	Multicast Control Channel
MCH	Multicast Channel
MIMO	Multiple Input Multiple Output
MME	Mobility Management Entity
MTCH	MBMS Traffic Channel
MU-MIMO	Multi User MIMO
NACK	Negative Acknowledgement
NAS	Non Access Stratum
OFDM	Orthogonal Frequency Division Multiplexing
OFDMA	Orthogonal Frequency Division Multiple Access
OPEX	Operational Expenditures
PAPR	Peak-to-Average Power Ratio
PDCCH	Physical Downlink Control Channel
PCCH	Paging Control Channel
PCH	Paging Channel
PDCP	Packet Data Convergence Protocol
PHY	Physical Layer
QAM	Quadrature Amplitude Modulation
QoS	Quality of Service
QPSK	Quadrature Phase Shift Keying
PAPR	Peak to Average Power Ratio
PDSCH	Physical Downlink Shared Channel
PDU	Protocol Data Unit
PS	Packet Switched

LTE/E-UTRA

PUCCH	Physical Uplink Control Channel
PUSCH	Physical Uplink Shared Channel
RACH	Random Access Channel
RAN	Radio Access Network
RAT	Radio Access Technology
RB	Radio Bearer
RF	Radio Frequency
RLC	Radio Link Control
RRC	Radio Resource Control
RRM	Radio Resource Management
RU	Resource Unit
S1	Interface between eNB and aGW
S1-C	S1-Control plane
S1-U	S1-User plane
SAE	System Architecture Evolution
SC-FDMA	Single Carrier – Frequency Division Multiple Access
SCH	Synchronization Channel
SDMA	Spatial Domain Multiple Access
SU-MIMO	Single User MIMO
TDD	Time Division Duplex
TS	Technical Specification
TTI	Transmission Time Interval
UE	User Equipment
UL	Uplink
UL-SCH	Uplink Shared Channel
UMTS	Universal Mobile Telecommunications System
UPE	User Plane Entity
U-plane	User plane
UTRA	UMTS Terrestrial Radio Access
UTRAN	UMTS Terrestrial Radio Access Network
VoIP	Voice over IP
WCDMA	Wideband Code Division Multiple Access
WLAN	Wireless Local Area Network
X2	Interface between eNBs
X2-C	X2-Control plane
X2-U	X2-User plane

10 Additional Information

This application note is updated from time to time. Please visit the website [1MA111](#) to download the latest version.

Please send any comments or suggestions about this application note to TM-Applications@rsd.rohde-schwarz.com.

11 References

- [1] 3GPP TS 25.913; Requirements for E-UTRA and E-UTRAN (Release 7)
- [2] 3GPP TR 25.892; Feasibility Study for Orthogonal Frequency Division Multiplexing (OFDM) for UTRAN enhancement (Release 6)
- [3] 3GPP TS 36.211; Physical Channels and Modulation (Release 8)
- [4] 3GPP TS 36.300; E-UTRA and E-UTRAN; Overall Description; Stage 2 (Release 8)
- [5] 3GPP TS 22.978; All-IP Network (AIPN) feasibility study (Release 7)

12 Ordering Information

Vector Signal Generator		
R&S® SMU200A		1141.2005.02
R&S® SMU-B102	Frequency range 100 KHz to 2.2GHz for 1st RF Path	1141.8503.02
R&S® SMU-B103	Frequency range 100 KHz to 3GHz for 1st RF Path	1141.8603.02
R&S® SMU-B104	Frequency range 100 KHz to 4GHz for 1st RF Path	1141.8703.02
R&S® SMU-B106	Frequency range 100 KHz to 6 GHz for 1st RF Path	1141.8803.02
R&S® SMU-B202	Frequency range 100 KHz to 2.2 GHz for 2nd RF Path	1141.9400.02
R&S® SMU-B203	Frequency range 100 KHz to 3 GHz for 2nd RF Path	1141.9500.02
R&S® SMU-B9	Baseband Generator with digital modulation (realtime) and ARB (128 M Samples)	1161.0766.02
R&S® SMU-B10	Baseband Generator with digital modulation (realtime) and ARB (64MSamples)	1141.7007.02
R&S® SMU-B11	Baseband Generator with digital modulation (realtime) and ARB (16MSamples)	1159.8411.02
R&S® SMU-B13	Baseband Main Module	1141.8003.02
R&S® SMU-K55	Digital Standard 3GPP LTE/EUTRA	1408.7310.02
R&S® SMU-K255	Digital Standard 3GPP LTE/EUTRA for WinIQSIM2	1408.7362.02
R&S® SMJ100A		1403.4507.02
R&S® SMJ-B103	Frequency range 100 kHz - 3 GHz	1403.8502.02
R&S® SMJ-B106	Frequency range 100 kHz - 6 GHz	1403.8702.02
R&S® SMJ-B9	Baseband generator with digital modulation (realtime) and ARB (128 M Samples)	1404.1501.02
R&S® SMJ-B10	Baseband Generator with digital modulation (realtime) and ARB (64MSamples)	1403.8902.02
R&S® SMJ-B11	Baseband Generator with digital modulation	1403.9009.02

LTE/E-UTRA

	(realtime) and ARB (16MSamples)	
R&S® SMJ-B13	Baseband Main Module	1403.9109.02
R&S® SMJ-K55	Digital Standard 3GPP LTE/EUTRA	1409.2206.02
R&S® SMJ-K255	Digital standard 3GPP LTE/EUTRA for WinIQSIM2	1409.2258.02
R&S® SMATE200A		1400.7005.02
R&S® SMATE-B103	Frequency range 100 KHz to 3 GHz for 1st RF Path	1401.1000.02
R&S® SMATE-B106	Frequency range 100 KHz to 6 GHz for 1st RF Path	1401.1200.02
R&S® SMATE-B203	Frequency range 100 KHz to 3 GHz for 2nd RF Path	1401.1400.02
R&S® SMATE-B206	Frequency range 100 kHz - 6 GHz for 2nd RF path	1401.1600.02
R&S® SMATE-B9	Baseband Generator with digital modulation (real time) and ARB (128 M samples)	1404.7500.02
R&S® SMATE-B10	Baseband Generator with digital modulation (realtime) and ARB (64MSamples)	1401.2707.02
R&S® SMATE-B11	Baseband Generator with digital modulation (realtime) and ARB (16MSamples)	1401.2807.02
R&S® SMATE-B13	Baseband Main Module	1401.2907.02
R&S® SMATE-K55	Digital Standard 3GPP LTE/EUTRA	1404.7851.02
R&S® AMU200A	Baseband signal generator, base unit	1402.4090.02
R&S® AMU-B9	Baseband generator with digital modulation (realtime) and ARB (128 MSamples)	1402.8809.02
R&S® AMU-B10	Baseband generator with dig. modulation (realtime) and ARB (64 MSamples)	1402.5300.02
R&S® AMU-B11	Baseband generator with dig. modulation (realtime) and ARB (16 MSamples)	1402.5400.02
R&S® AMU-B13	Baseband main module	1402.5500.02
R&S® AMU-K55	Digital Standard LTE/EUTRA	1402.9405.02
R&S® AMU-K255	Digital Standard LTE/EUTRA for WinIQSIM2	1402.9457.02
R&S® AFQ100A	IQ modulation generator base unit	1401.3003.02
R&S® AFQ-B10	Waveform memory 256 Msamples	1401.5106.02
R&S® AFQ-B11	Waveform memory 1Gsamples	1401.5206.02
R&S® AFQ-K255	Digital Standard LTE/EUTRA, WinIQSIM 2 required	1401.5906.02
Signal Analyzer		
R&S® FSQ3	20 Hz to 3.6 GHz	1155.5001.03
R&S® FSQ8	20 Hz to 8 GHz	1155.5001.08
R&S® FSQ26	20 Hz to 26,5 GHz	1155.5001.26
R&S® FSQ40	20 Hz to 40 GHz	1155.5001.40
R&S® FSQ-K100	Application Firmware 3GPP LTE/EUTRA Downlink	1308.9006.02
R&S® FSQ-K101	Application Firmware 3GPP LTE/EUTRA Uplink	1308.9058.02



ROHDE & SCHWARZ GmbH & Co. KG · Mühldorfstraße 15 · D-81671 München · Postfach 80 14 69 · D-81614 München ·
Tel (089) 4129 -0 · Fax (089) 4129 - 13777 · Internet: <http://www.rohde-schwarz.com>

*This application note and the supplied programs may only be used subject to the conditions of use set forth in the
download area of the Rohde & Schwarz website.*