

# Voice and SMS in LTE

## White Paper

This white paper summarizes the technology options for supporting voice and short message service (SMS) in LTE, including circuit switched fallback (CSFB), SMS over SGs, and voice over LTE (VoLTE). It includes background information on the standardization process, and the commercial implications for the different options. The white paper also addresses test and measurement requirements resulting from the support of voice and SMS in LTE.

# Table of Contents

|           |   |           |
|-----------|---|-----------|
| <b>1</b>  | <b>Introduction .....</b>                               | <b>3</b>  |
| <b>2</b>  | <b>Overview .....</b>                                   | <b>3</b>  |
| <b>3</b>  | <b>Circuit switched fallback (CSFB) .....</b>           | <b>5</b>  |
| 3.1       | Circuit switched fallback to GERAN or UTRAN .....       | 5         |
| 3.2       | Circuit switched fallback to 1xRTT .....                | 10        |
| <b>4</b>  | <b>SMS over SGs.....</b>                                | <b>15</b> |
| <b>5</b>  | <b>Support of voice and SMS via IMS .....</b>           | <b>18</b> |
| 5.1       | Overview of the IMS framework.....                      | 19        |
| 5.2       | EPS attach and P-CSCF discovery .....                   | 23        |
| 5.3       | IMS registration, authentication and key agreement..... | 24        |
| 5.4       | Obtaining voice services via IMS.....                   | 27        |
| 5.5       | Radio aspects .....                                     | 29        |
| 5.6       | Obtaining SMS services via IMS.....                     | 31        |
| 5.7       | Single radio voice call continuity .....                | 34        |
| <b>6</b>  | <b>Test solutions for voice and SMS in LTE.....</b>     | <b>35</b> |
| 6.1       | Verifying the terminal protocol stack.....              | 35        |
| 6.2       | Voice quality testing .....                             | 39        |
| <b>7</b>  | <b>Conclusion.....</b>                                  | <b>40</b> |
| <b>8</b>  | <b>Literature.....</b>                                  | <b>40</b> |
| <b>9</b>  | <b>Additional information.....</b>                      | <b>42</b> |
| <b>10</b> | <b>Abbreviations .....</b>                              | <b>42</b> |

# 1 Introduction

For mobile network operators, voice and short message service (SMS) have consistently been major sources of revenue. Optimum support of these conventionally circuit switched services in data-oriented LTE is essential. This white paper summarizes the technology options for supporting voice and SMS in LTE, including circuit switched fallback (CSFB), SMS over SGs, and voice over LTE (VoLTE). It includes background information on the standardization process, and the commercial implications for the different options. The white paper also addresses test and measurement requirements resulting from the support of voice and SMS in LTE. This includes terminal protocol testing and voice quality testing.

Basic understanding of the LTE access stratum and non-access stratum protocol architecture is assumed. For a detailed introduction to LTE technology, please refer to [1].

## 2 Overview

LTE was specified by the 3<sup>rd</sup> Generation Partnership Project (3GPP) in release 8. LTE is designed as a pure packet switched system. Legacy circuit switched services are no longer supported. This implies that support of voice within LTE has to be done with voice over IP.

Supporting voice over IP in a cellular communication system brings a lot of new challenges. Subscribers expect the same quality of service they know from circuit switched voice services, in GSM networks for example. Network operators worldwide have invested heavily in their established circuit switched networks, so moving the voice services to a new technology must have clear commercial and technical advantages for them. Additionally, LTE is complex and designing the LTE technical specifications has taken time. 3GPP release 8 was just the first release of the LTE standard, with many enhancements added in the release 9 specifications. For these reasons, many network operators have decided to deploy their first commercial LTE networks focusing on support for data services, by providing data dongles as terminals for high-speed internet connectivity. Voice service support is provided by the legacy networks in this first phase of LTE deployment.

Voice support in LTE requires the right mechanisms and architecture in radio and core networks, to guarantee quality of service and a good user experience. But it is not only the LTE network that is affected: nationwide LTE coverage can hardly be achieved from day one onwards. Thus, subscriber mobility between LTE and legacy GSM, UMTS HSPA/HSPA+, and CDMA2000® 1xRTT/EV-DO<sup>1)</sup> networks is a key requirement. This is important, to achieve a seamless service experience for all services, including voice as soon as it will be provided within LTE.

<sup>1)</sup> CDMA2000® is a registered trademark of the Telecommunications Industry Association (TIA -USA).

When it comes to voice support in LTE, the IP Multimedia Subsystem (IMS) is a key technology. IMS provides a framework for supporting IP based services and requires new IMS-specific network elements as part of the dedicated core network architecture. The first version of IMS was standardized in 3GPP release 5, with many enhancements specified in subsequent releases.

In the early days of LTE standardization, it had been assumed that IMS would be commercially available when the first LTE networks were deployed. Voice support was also considered as being addressed by IMS. However, rollout of IMS was slower than expected, with the result that voice support in LTE had become a real challenge for many network operators.

Alternatives and intermediate solutions for supporting voice services in LTE were investigated more deeply. The most important and commercially relevant one is the circuit switched fallback which basically provides subscribers with voice services via the legacy networks GSM, UMTS, or CDMA2000@ 1xRTT. The users “fall back” to one of these technologies as soon as they initiate a voice call within LTE coverage or if they accept a terminating voice call. CSFB has become the recommended solution for network operators who are looking for an intermediate non-IMS voice solution. A related recommendation from the Next Generation Mobile Networks (NGMN) organization was launched [2]. The first LTE networks are already using CSFB for voice support. CSFB is also supporting a variety of roaming scenarios, ensuring that existing circuit switched roaming agreements can be met.

A closely related topic to support of voice is the support of SMS as another key circuit switched service. SMS is a huge revenue driver for network operators worldwide. A non-IMS based solution for SMS was specified by 3GPP, the “SMS over SGs” solution for GSM and UMTS networks, where SGs is the name of a core network internal interface. SMS over SGs allows network operators to support SMS as a circuit switched service within LTE. In October 2009, the industry initiative NGMN announced the recommendation to implement “SMS only over SGs” as a minimal requirement to enable roaming [2].

In the long run, support of voice and messaging in LTE over IMS remains the major target. A related industry initiative is VoLTE (Voice over LTE). It was formally announced in February 2010 [3] by the network operator organization GSMA (Global System for Mobile Communications Association). VoLTE has developed the framework for optimum support of voice and SMS over IMS in LTE, including roaming and interconnect issues. VoLTE is based on existing IMS multimedia telephony (MMTel) concepts [4].

Currently there is quite a variety of scenarios, technology options, and deployment scenarios. In the following sections, the different techniques to support voice and SMS in LTE will be explained in more detail. Support of these techniques, CSFB, SMS over SGs, and VoLTE, also implies new test and measurement requirements in the development and verification of terminals and networks. This white paper highlights possibilities to test the functionality and the performance of voice and SMS services. The focus is on terminal testing. Especially when it comes to voice over IP, evaluating voice quality and voice call performance are key issues for both manufacturers and network operators. For testing voice quality, reliable and industry-established mechanisms are already available which will be introduced in this paper.

## 3 Circuit switched fallback (CSFB)

CSFB is the mechanism to move a subscriber from LTE to a legacy technology to obtain circuit switched voice service. This function is only available if LTE coverage is overlapped by GSM, UMTS, or CDMA2000® 1xRTT coverage.

CSFB was already specified in 3GPP release 8, with further enhancements defined in 3GPP release 9. A number of different CSFB mechanisms are available, and there are also differences depending on the radio technology the subscriber falls back to. CSFB to GSM, UMTS, and CDMA2000® 1xRTT is defined, but please note that as of 3GPP release 9, no mechanisms are specified to support CSFB to both UMTS/GSM and CDMA2000® 1xRTT in the same PLMN (public land mobile network). This holds true even in case the UE would support both.

Let us first have a look at the CSFB mechanisms for UMTS and GSM, followed by CSFB to CDMA2000® 1xRTT.

### 3.1 Circuit switched fallback to GERAN or UTRAN

CSFB affects the radio and the core networks. 3GPP technical specification (TS) 23.272 [5] is the stage 2 specification of CSFB, providing an overview of the architecture and procedures used. Figure 1 taken from TS 23.272 shows the Evolved Packet System (EPS) architecture for CSFB. It includes the interfaces between the different radio access network types and the core network entities. UTRAN is the UMTS terrestrial radio access network, GERAN is the GSM/EDGE radio access network, and E-UTRAN is the evolved universal terrestrial radio access network of LTE. To support circuit switched services, a connection to the mobile switching center (MSC) server has to be established. The mobility management entity (MME) of the evolved packet system interfaces to the MSC server via the SGs interface. The CSFB mechanism is implemented using this SGs interface.

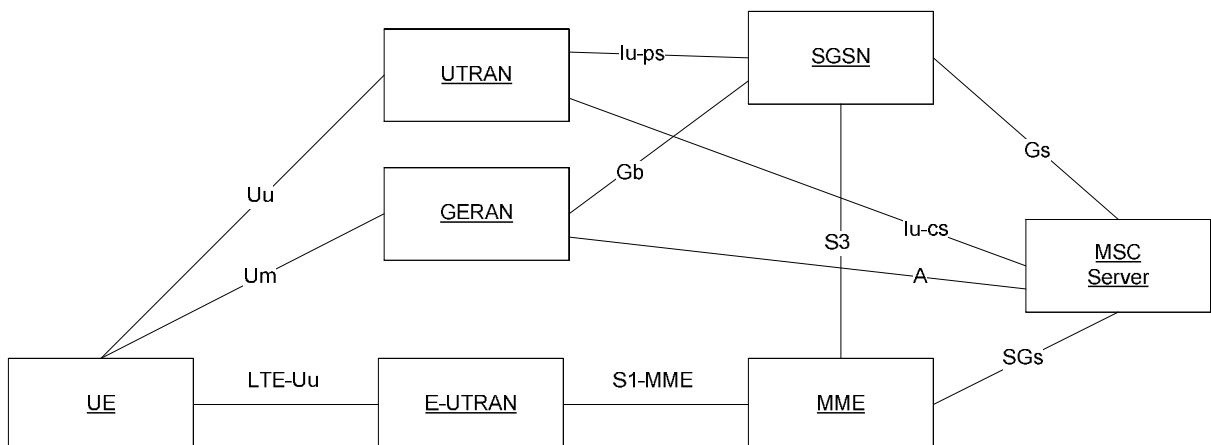

Figure 1: Evolved Packet System (EPS) architecture for CSFB [4]

Several CSFB solutions exist for the various target radio access technologies (RATs). Table 1 shows an overview of the CSFB options for GSM and UMTS, as specified in 3GPP release 8 and 3GPP release 9 [6]. For each solution, the table indicates whether the solution is mandatory for the terminal (user equipment, UE) or optional. If a solution is optional, it is specified as UE capability [7]. Table 1 also indicates if a solution is bound to a certain feature group indicator (FGI). The concept of feature groups was introduced (independent from CSFB) in order to facilitate early terminal availability for LTE [8]. For certain features of the specification it was anticipated it would be hard to conduct proper conformance and interoperability testing due to possibly missing coverage in test specifications and lack of implementations supporting the feature. However, the features remain mandatory in the specifications. Using feature group indicators, early LTE UEs can signal support of a particular feature to the network by setting the corresponding feature group indicator to 1.

**Table 1: CS fallback options to UMTS and GSM [6]**

| Target RAT   | Solutions  | Release | UE Capability  | FGI Index   |
|--|--|---------|--|-------------|
| CS fallback to UMTS  | RRC Connection Release with Redirection without Sys Info | Rel-8   | (NOTE 1)<br>Mandatory for UEs supporting CS fallback to UMTS |             |
|  | RRC Connection Release with Redirection with Sys Info    | Rel-9   | (NOTE 1)<br>e-RedirectionUTRA                                |             |
|  | PS handover with DRB(s)                                  | Rel-8   | (NOTE 1)<br>Mandatory for UEs supporting CS fallback to UMTS | FGI8, FGI22 |
| CS fallback to GSM   | RRC Connection Release with Redirection without Sys Info | Rel-8   | (NOTE 2)<br>Mandatory for UEs supporting CS fallback to GSM  |             |
|  | RRC Connection Release with Redirection with Sys Info    | Rel-9   | (NOTE 2)<br>e-RedirectionGERAN                               |             |
|  | Cell change order without NACC                           | Rel-8   | (NOTE 2)<br>Mandatory for UEs supporting CS fallback to GSM  | FGI10       |
|  | Cell change order with NACC                              | Rel-8   | (NOTE 2)<br>Mandatory for UEs supporting CS fallback to GSM  | FGI10       |
|  | PS handover  | Rel-8   | (NOTE 2)<br>interRAT-PS-HO-ToGERAN                           |             |
| NOTE 1: All CS fallback to UMTS capable UE shall indicate that it supports UTRA FDD or TDD and supported band list in the UE capability. |  |         |  |             |
| NOTE 2: All CS fallback to GSM capable UE shall indicate that it supports GERAN and supported band list in the UE capability.            |  |         |  |             |

Table 1 shows three different possibilities for CSFB to UMTS, two using the RRC connection release with redirection mechanism, and one using the packet switched (PS) handover mechanism. For CSFB to GERAN, there are five possibilities. As addition to the RRC connection release with redirection and the PS handover mechanisms, cell change order (with or without network assisted cell change, NACC) can be used.

Let us first have a look at the **RRC connection release with redirection**. RRC stands for radio resource control which is the layer 3 control plane protocol over the LTE air interface, terminating in the UE and in the base station (termed eNodeB in LTE). Establishing an RRC connection between a UE and a base station is the prerequisite for exchanging further signalling information and user data transfer. For CSFB, there will always be an RRC connection established in order to exchange signalling messages for initiating and preparing the fallback. In the case of a terminating voice call, the UE has to receive a paging message. In the case of a mobile originating call, the UE has to send a service request message. The UE may also be involved in a data transfer when a voice call has to be set up.

RRC connection release with redirection is used to terminate the RRC connection, and at the same time provides redirection information to the terminal related to the target cell of the (target) radio access technology. The procedure is initiated by the base station; it is specified in [8]. Figure 2 illustrates base station (as E-UTRAN entity) sending an *RRCCConnectionRelease* message to the UE.

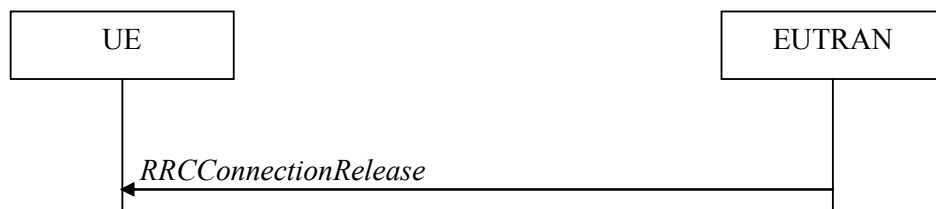

**Figure 2: RRC connection release procedure [8]**

If redirection to another radio access technology shall take place, the redirection information is contained in the *RRCCConnectionRelease* message. The information element *redirectedCarrierInfo* (specified in 3GPP release 8) indicates a carrier frequency on the intended radio access technology where the terminal shall fall back to. The terminal uses the carrier to select an acceptable cell to camp on.

The complete message flow for CSFB with RRC connection release and redirection to GERAN or UTRAN is shown in Figure 3. As an example, the case of a successful mobile terminated call is shown. The UE is assumed to be engaged in a data session in LTE (active mode) when the call arrives.

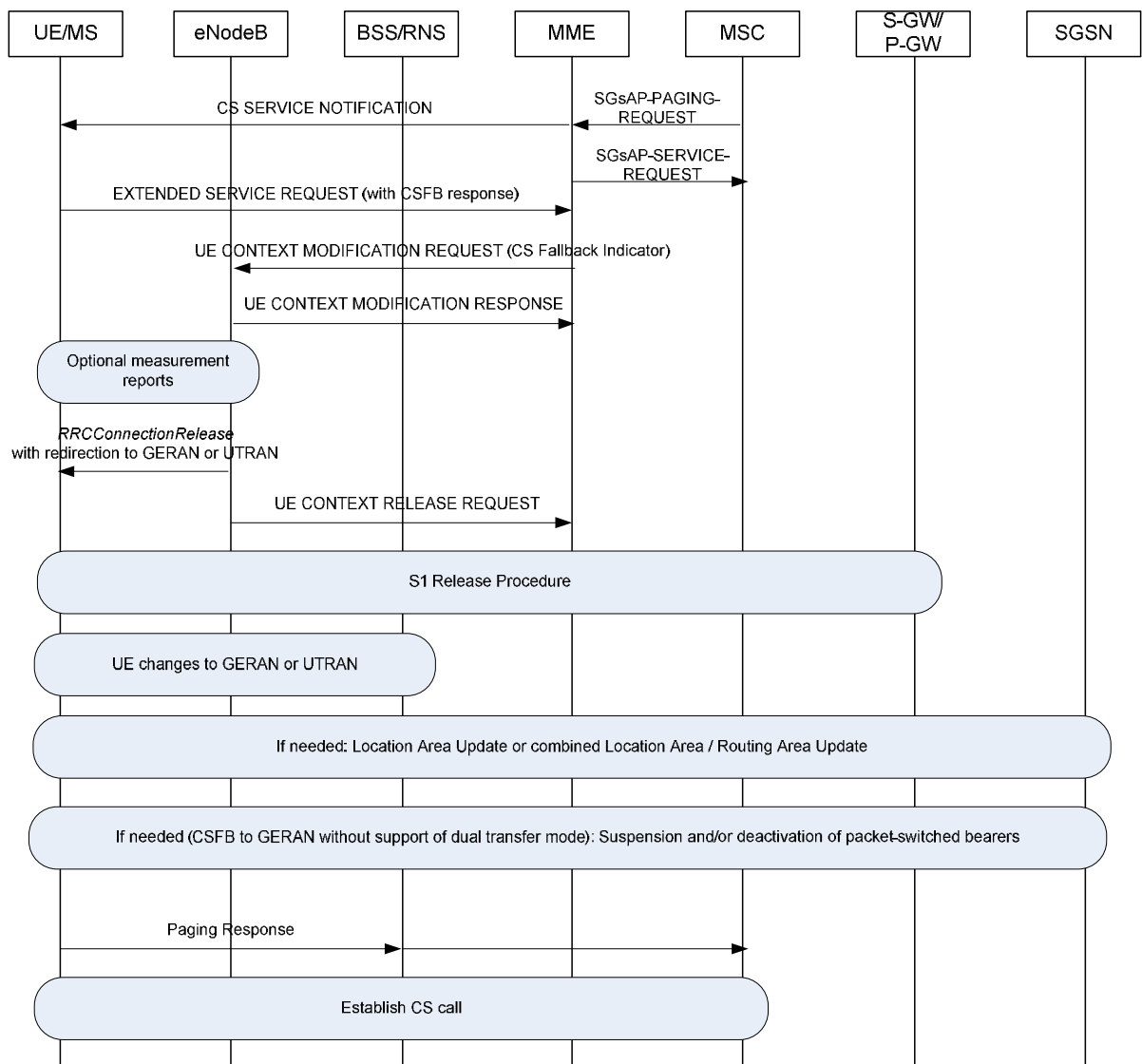

**Figure 3: CSFB to UTRAN or GERAN using RRC connection release with redirection, mobile terminated call, based on [5]**

CSFB support by the UE is shown by the information element "Voice domain preference and UE's usage setting" in the ATTACH REQUEST message. When the MSC receives an incoming voice call it sends a paging request to the MME over the SGs interface. This example assumes that the terminal has an active data session. The MME has already established an S1 connection and sends the CS SERVICE NOTIFICATION message [10] to the UE (otherwise the UE would have to be paged in a first step). The MME informs the MSC with the SERVICE REQUEST message over SGs that the UE was in connected mode. Upon receiving the CS SERVICE NOTIFICATION message, the UE will send an EXTENDED SERVICE REQUEST message [10]. This message is used to respond to the CS fallback request from the network and includes a "CSFB response" indicator that indicates whether the UE accepts or rejects a paging for CS fallback. Assuming the CSFB has been accepted, the MME will then inform the eNodeB with a UE CONTEXT MODIFICATION REQUEST [11] that the UE should be moved to UTRAN or GERAN by means of a CS fallback.



The eNodeB may request measurement reports of UTRAN or GERAN target cells from the UE to determine a suitable carrier frequency on the target radio access technology for CSFB. In the example in Figure 3, RRC connection release with redirection to GERAN or UTRAN is now triggered by the network. Afterwards, the eNodeB requests the MME to release the S1 connection for the UE with the UE CONTEXT RELEASE REQUEST message [11]. This message also specifies whether the UE would be able to receive packet switched services in the target cell. The S1 signaling connection and all S1 bearers are released.

The UE selects a cell of the target radio access technology and establishes a radio signaling connection with this cell. If the location area of the target cell is different from the one stored in the UE, the UE initiates a Location Area Update or a Combined Routing Area / Location Area Update procedure. If this is not required, the UE directly responds to the paging with the appropriate UTRAN or GERAN procedures. The CS call can be established by the MSC.

One special aspect is the handling of any established packet switched bearers. For CSFB to UTRAN they can be resumed in the target cell. For a GERAN target cell, if the UE or the network do not support dual transfer mode (DTM), the packet service can not be maintained in parallel to the voice service. The UE will then have to initiate suspension of the non-guaranteed bit rate packet switched bearers (the guaranteed bit rate bearers are deactivated). The MME records the UE is in suspended status in the UE context.

For CSFB to UMTS, a further optimization is possible. Using a 3GPP release 7 feature "**Deferred measurement control reading**", the UE defers reading system information blocks type 11, 11bis and 12 in the UMTS target cell [9]. These system information blocks contain measurement control information, such as lists of cells where the UE is supposed to do measurements. By deferring reading these system information blocks, the CSFB procedure can be accelerated and the call setup delay is reduced. Support of this feature is indicated in the information element "Deferred measurement control UTRAN support" in System Information Block type 3. The UE informs the network in the RRC CONNECTION SETUP COMPLETE message (and possibly in subsequent RRC messages like RADIO BEARER SETUP COMPLETE) if it has not yet read the system information blocks type 11, 11bis or 12.

In 3GPP release 9, the redirection information was further enhanced in the *RRConnectionRelease* message to improve the CSFB mechanism and further reduce call setup delays. The **RRC connection release with redirection now also includes system information** of one or more GERAN or UTRAN cells on the redirected carrier frequency. The system information of the cell according to GERAN or UTRAN protocols is provided in a System Information Container within the *RRConnectionRelease* message. For UMTS target cells, for example, this includes the Master Information Block and System Information Block types 1, 3, 5, 7, and optionally 11, 11bis and 12 and scheduling blocks. No reception of system information is needed in the redirected cell before accessing it. Support of redirection with system information is optional for the UE [7]. The UE capability *e-RedirectionUTRA* defines whether the UE supports using UMTS system information provided by the *RRConnectionRelease* message. The UE capability *e-RedirectionGERAN* defines whether the UE supports using GSM system information provided by the *RRConnectionRelease* message.

**PS handover** is another alternative for CSFB to GERAN or UTRAN. PS handover to GERAN is a UE capability (interRAT-PS-HO-ToGERAN in [7]), while PS handover to UTRAN is mandatory for UEs supporting CSFB to UMTS.

The PS handover is initiated by the eNodeB to move the packet switched bearers to the target radio access technology. This has the advantage that the bearers are not interrupted. For CSFB based on RRC connection release, they are interrupted.

The *MobilityFromEUTRACCommand* message is used to command handover from E-UTRAN to GERAN or UTRAN, see Figure 4. It is sent from the base station to the UE.

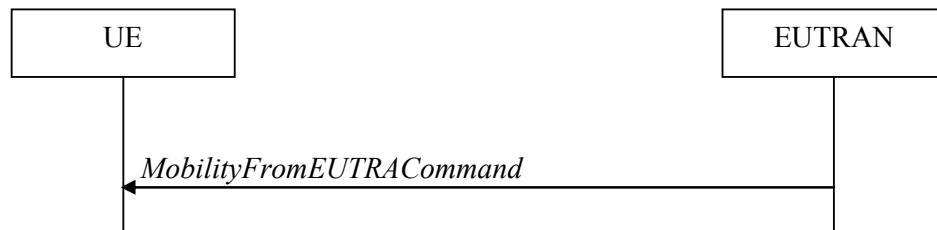

**Figure 4: Mobility from E-UTRA [8]**

The same procedure is used for a **cell change order** to GERAN. Cell change order is another option for CSFB, but only available for CSFB to GERAN. Cell change order can be enhanced with network-assisted cell change (NACC) information; system information of the target cell. NACC reduces the service outage time.

For a mobile originated voice call, the message sequence starts with a NAS EXTENDED SERVICE REQUEST message [10] sent from the UE to the MME, including a CSFB indicator. The CSFB is then executed via one of the options mentioned above (RRC connection release with redirection with or without system information, PS handover, cell change order to GERAN with or without NACC). The UE will establish the voice call in the target cell.

The specifications do not require the UE to move back to E-UTRAN after finishing the voice call within the GERAN or UTRAN. The UE may remain in GERAN or UTRAN. This is handled by existing mobility mechanisms and is not part of CSFB specifications. When the UE moves to E-UTRAN, the UE can resume the EPS bearers that were suspended in course of the CSFB.

## 3.2 Circuit switched fallback to 1xRTT

For CSFB to 1xRTT, the UE can establish voice service by falling back from E-UTRAN to the CDMA2000® 1xRTT network. Compared to CSFB for UMTS and GSM, some 1xRTT-specific features apply.

Figure 5 shows the reference architecture for CSFB to 1xRTT [5]. It includes the S102 reference point between the MME and the 1xCS IWS (circuit switched fallback interworking solution function for 3GPP2 1xCS). The S102 reference point provides a tunnel between the MME and the 1xCS IWS to relay 1xCS signalling messages.

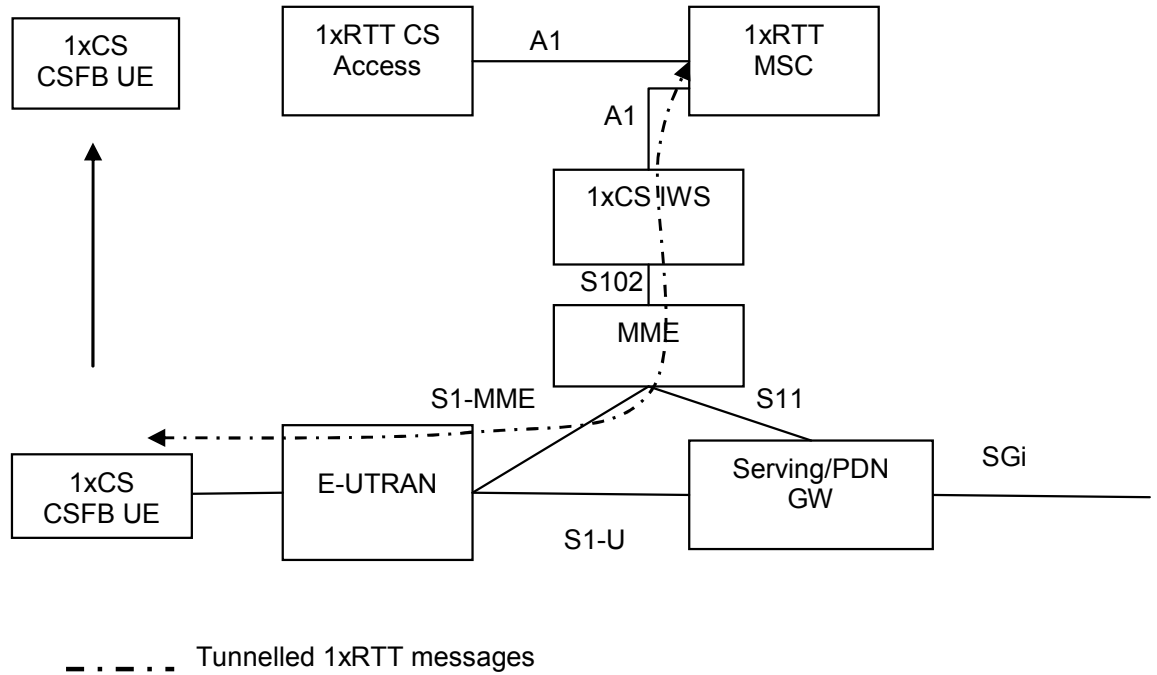

Figure 5: Reference architecture for CSFB to 1xRTT [5]

Table 2 shows an overview of the CSFB to 1xRTT options from 3GPP release 8 and 3GPP release 9 [6]. The table also shows the related UE capabilities and feature group indicators.

Table 2: CS fallback options to 1xRTT [6]

| Target RAT  | Solutions   | Release | UE Capability  | FGI Index    |
|---|---|---------|--|--------------|
| CS fallback to 1xRTT  | RRC Connection Release with Redirection                           | Rel-8   | (NOTE 1)<br>Mandatory for UEs supporting CS fallback to 1xRTT              |              |
|   | enhanced 1xCSFB   | Rel-9   | (NOTE 1)<br>e-CSFB-1XRTT   |              |
|   | enhanced 1xCSFB with concurrent HRPD handover                     | Rel-9   | (NOTE 1)<br>e-CSFB-ConcPS-Mob1XRTT, Support of HRPD, supportedBandListHRPD | FGI12, FGI26 |
|   | dual receiver 1xCSFB (RRC Connection Release without Redirection) | Rel-9   | (NOTE 1)<br>rx-Config1XRTT (set to 'dual')                                 |              |
| NOTE 1: All CS fallback to 1xRTT capable UE shall indicate that it supports 1xRTT and supported band list in the UE capability. |   |         |  |              |

There are four possibilities for CSFB to 1xRTT as shown in Table 2. The first option is the RRC connection release with redirection mechanism. This is the only mechanism available in 3GPP release 8 and mandatory for UEs supporting CSFB to 1xRTT. 3GPP release 9 added further options to support CSFB to 1xRTT. The enhanced 1xCSFB uses 1xRTT handover signalling tunnelled between the UE and the 1xRTT network. Enhanced 1xCSFB is a UE capability named e-CSFB-1XRTT [7]. Enhanced 1xCSFB can also be concurrent with a packet switched handover to High Rate Packet Data (HRPD), if supported by the UE. Support for enhanced 1xCSFB with concurrent HRPD handover is indicated by the UE capability e-CSFB-ConcPS-Mob1XRTT [7]. Dual receiver 1xCSFB can be used by dual receiver UEs: the RRC connection can be released without redirection information and services can be obtained in the 1xRTT network. Dual receiver 1xCSFB is a UE capability, named rx-Config1XRTT [7].

A 1xCSFB capable terminal may pre-register in the 1xRTT network via E-UTRAN to establish a presence with the 1xRTT network in advance of CSFB. Pre-registration only applies to 1xCSFB of 3GPP release 8 and to enhanced 1xCSFB. It does not apply to dual receiver 1xCSFB, as a dual-receiver UE uses the normal registration procedure to register in the 1xRTT network. The UE is informed via system information whether pre-registration in the 1xRTT domain shall be carried out (information element *csfb-RegistrationParam1XRTT* in *SystemInformationBlockType8* message). Before the UE can pre-register, the UE needs to receive CDMA2000® 1xRTT parameters from the 1xRTT network such as system and network identification. The dedicated RRC procedure CSFB to 1x Parameter transfer [8] is used, see Figure 6.

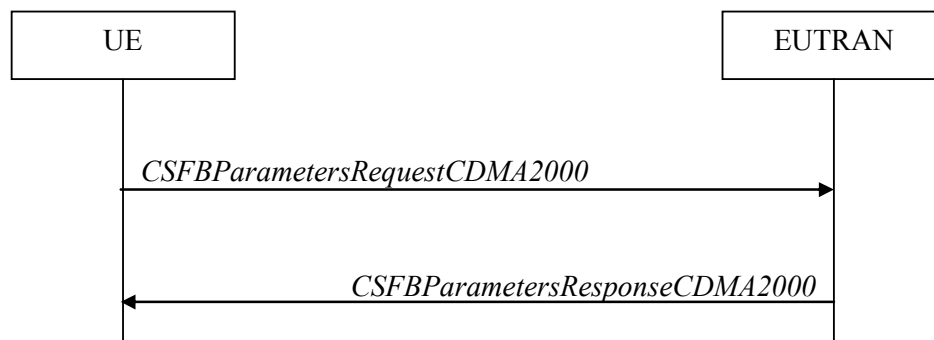

Figure 6: CSFB to 1x Parameter transfer [8]

The UE initiates the CSFB to 1x Parameter transfer procedure upon request from the CDMA2000® upper layers, and sends the *CSFBParametersRequestCDMA2000* message. The response message *CSFBParameterResponseCDMA2000* contains the necessary parameters. The 1xRTT-specific protocol information is always transparent to the E-UTRAN. The 1xRTT-specific parameters sent in the *CSFBParameterResponseCDMA2000* message are pre-configured in the LTE base station. The actual 1xRTT pre-registration procedure is then carried out transparently to the E-UTRAN between the UE and the 1xRTT network (using NAS uplink / downlink information transfer and uplink/downlink S1 CDMA2000 tunnelling mechanism). Depending on the requirements of the 1xRTT network, the UE performs periodic re-registration on the 1xRTT network. This does not apply to dual receiver UEs. Regarding the actual CSFB procedures, let us first have a look at the **RRC connection release with redirection**.

The complete message flow for CSFB to 1xRTT based on RRC connection release with redirection is shown as an example of a mobile originated call in Figure 7. It assumes that the UE is attached in the E-UTRAN and pre-registration with 1xRTT CS has taken place.

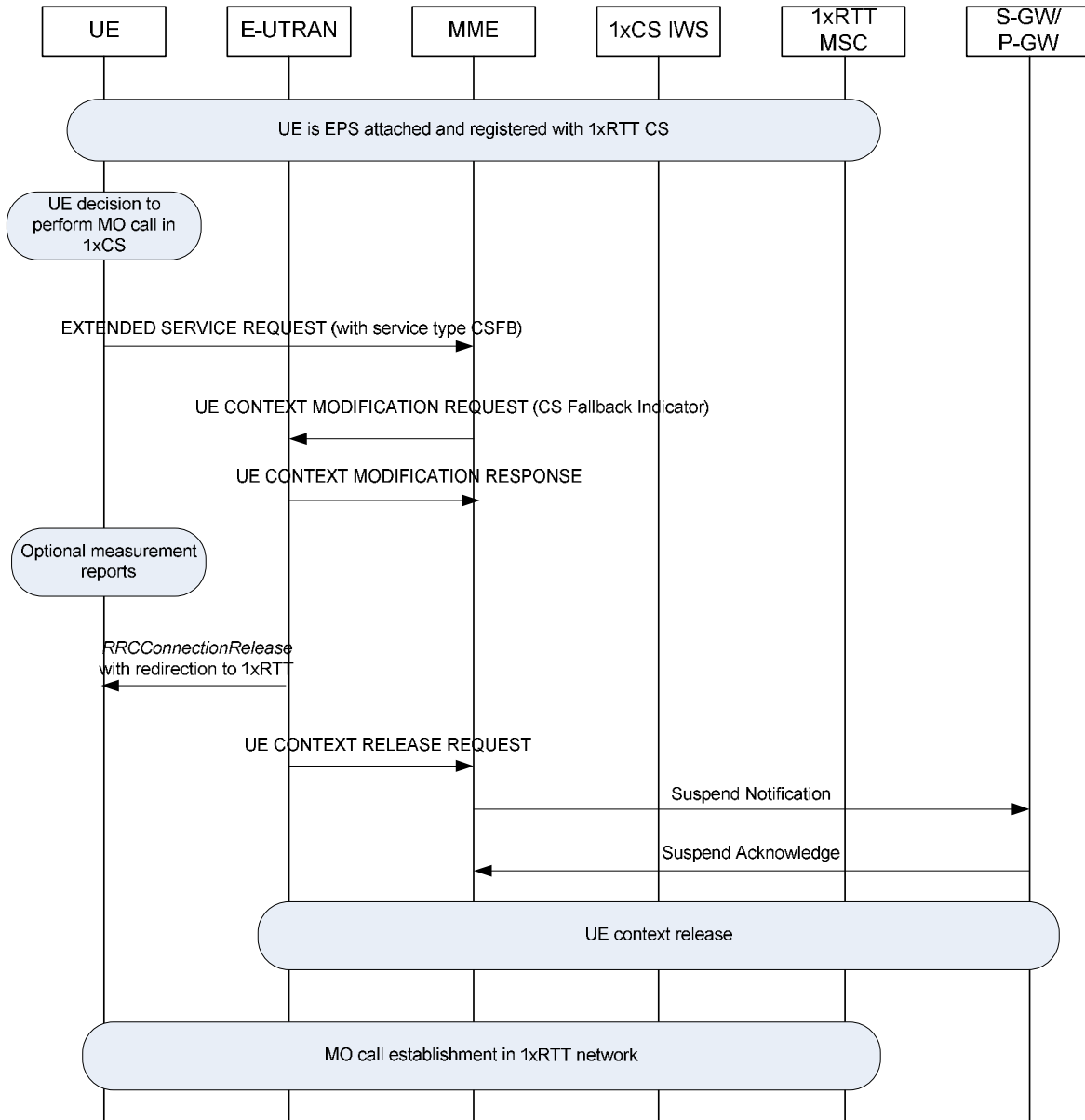
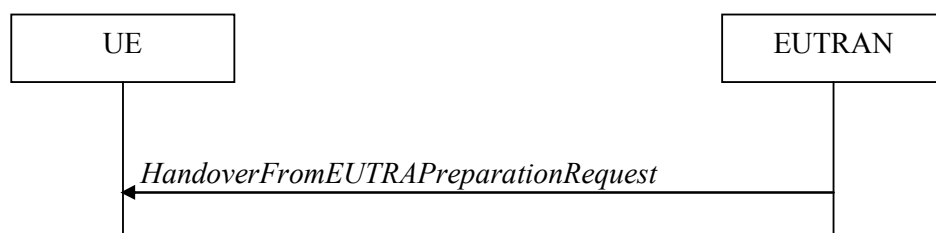

Figure 7: CSFB to 1xRTT using RRC connection release with redirection, mobile originated call, based on [5]

When the UE makes a mobile originated CS call, it sends an EXTENDED SERVICE REQUEST [10] to the MME, with the service type set to “mobile originating CS fallback or 1xCS fallback”. The MME then sends the UE CONTEXT MODIFICATION REQUEST [11] message to the E-UTRAN, indicating to the E-UTRAN that the UE has to be moved to 1xRTT. The E-UTRAN may request measurement reports on 1xRTT cells. The E-UTRAN then triggers the RRC connection release with redirection to 1xCS. Afterwards, the S1 UE context can be released. Guaranteed bit rate (GBR) bearers are deactivated, and non-GBR bearers are suspended. The UE moves to the 1xRTT network and performs the procedures according to 3GPP2 specifications for setting up a mobile originated call in the 1xRTT network. After finishing the call, the UE can return to E-UTRAN by the regular cell reselection procedure, and resume the suspended EPS bearers.

With **enhanced 1xCSFB (e1xCSFB)**, handover signalling is tunnelled between E-UTRAN and the 1xRTT network to prepare for fallback to the 1xRTT network by obtaining 1xRTT traffic channel resources.

The LTE base station sends a *HandoverFromEUTRAPreparationRequest* message, see Figure 8, before moving the UE to the 1xRTT network. This procedure triggers the UE to prepare for the enhanced 1xRTT CS fallback to CDMA2000® by requesting a connection with this network.



**Figure 8: Handover from E-UTRA preparation request [8]**

The *HandoverFromEUTRAPreparationRequest* message triggers the UE to send the *ULHandoverPreparationTransfer* message containing 1xRTT information, see Figure 9. Messages between the MME and the 1xCS IWS are tunnelled using the S102 interface to prepare to establish the CS connection in the 1xRTT network.



**Figure 9: UL handover preparation transfer [8]**

The response from the 1xRTT network triggers the LTE base station to send a *MobilityFromEUTRACommand* message including a tunnelled “CDMA2000 handover command”. It includes a 1xRTT channel assignment so that the UE acquires a traffic channel in the 1xRTT network.

In addition to enhanced 1xCSFB, **concurrent mobility to HRPD** can be used if the UE supports this feature. Two separate *ULHandoverPreparationTransfer* messages are triggered from the UE, one containing 1xRTT and the other HRPD information. The concurrent HRPD handover procedure is handled independently from the e1xCSFB procedure, except that responses from the 1xRTT and HRPD networks are combined by the LTE base station into a single *MobilityFromEUTRACommand* message. In parallel to the fallback to 1xRTT, the HRPD connection can be maintained.

For **dual receiver 1xCSFB**, network support is shown by *SystemInformationBlockType8* message (the information element is called *csfb-SupportForDualRxUEs-r9*).

A dual receiver UE maintains separate registration and mobility procedures for LTE and 1xRTT. No coordination is required between the E-UTRAN and the 1xRTT network.

A dual receiver UE can camp in 1xRTT while it is active in E-UTRAN. It can also receive paging messages from 1xRTT. However, dual receiver UEs may not be able to stay in E-UTRAN when they handle a voice call or perform registration signalling or location management signalling in 1xRTT. This is the case for UE implementations with one transmitter. These UEs have to leave the E-UTRAN in order to perform a voice call or do certain 1xRTT related signalling. They send an EXTENDED SERVICE REQUEST message in order to initiate the fallback to 1xRTT. The LTE base station sends an *RRConnectionRelease* message without including redirection information. The UE then performs the normal 1xCS call origination or termination procedure in the 1xRTT access network.

There are also UE implementations supporting full LTE and 1xRTT operation in parallel. They do not require any CSFB mechanism. This simultaneous operation of data services in LTE and voice in 1xRTT is also referred to as **SV-LTE** (Simultaneous Voice – LTE).

## 4 SMS over SGs

SMS over SGs is a mechanism to transmit circuit switched SMS over the LTE radio network. It is based on circuit switched infrastructure and is a transition solution before SMS over IMS (see chapter 5.6) is deployed. SMS over SGs was specified in 3GPP release 8.

The SGs is the reference point between the MME of the evolved packet system and the MSC server, see Figure 10. The protocol used to connect an MME to an MSC server is SGsAP. The protocol for transferring signalling messages is the Stream Control Transmission Protocol (SCTP).

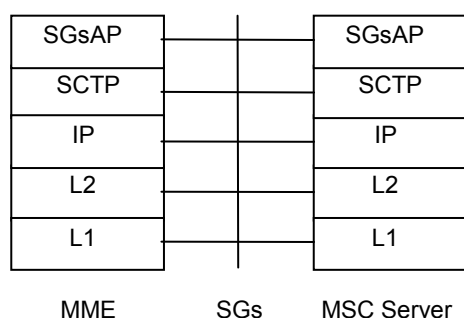

**Figure 10: SGs as reference point between MME and MSC Server [5]**

The SGs is used to handle mobility management and paging procedures between EPS and the CS domain (see Figure 1), and, for SMS, to deliver both mobile originating and mobile terminating SMS. The reference architecture for SMS over SGs for UMTS and GSM networks is shown in Figure 1. For 1xRTT networks, the mechanism to support SMS over S102 is specified accordingly [5].

SMS over SGs is independent from CS Fallback; meaning it does not trigger CS Fallback to UTRAN or GERAN. As no fallback takes place, SMS over SGs does not require overlapped coverage of LTE and legacy technologies.

Supporting SMS over SGs is mandatory for UE, MME and MSC entities supporting CS fallback. However, entities supporting SMS over SGs are not required to support CS fallback.

SMS over SGs (as well as CSFB) requires some slight modifications to the EPS attach procedure, which is based on the combined EPS/IMSI Attach procedure specified in [12]. Compared to the conventional attach, additional information about CS domain capabilities is exchanged. The EPS Attach Type in the ATTACH REQUEST message [10] indicates that the UE requests a combined EPS/IMSI attach and informs the network whether the UE requests "SMS only" services. For SMS service only (but not CSFB), the UE includes an "SMS-only" indication in the ATTACH REQUEST message. During the attach, the SGs association between MME and MSC/VLR (visitor location register) entities is created.

Figure 11 shows the delivery of a mobile originating SMS in idle mode and uses the following abbreviations:

- interworking MSC for SMS (SMS-IWMSC)
- service centre responsible for relaying and forwarding of SMS (SC)
- home location register / home subscriber server (HLR/HSS).



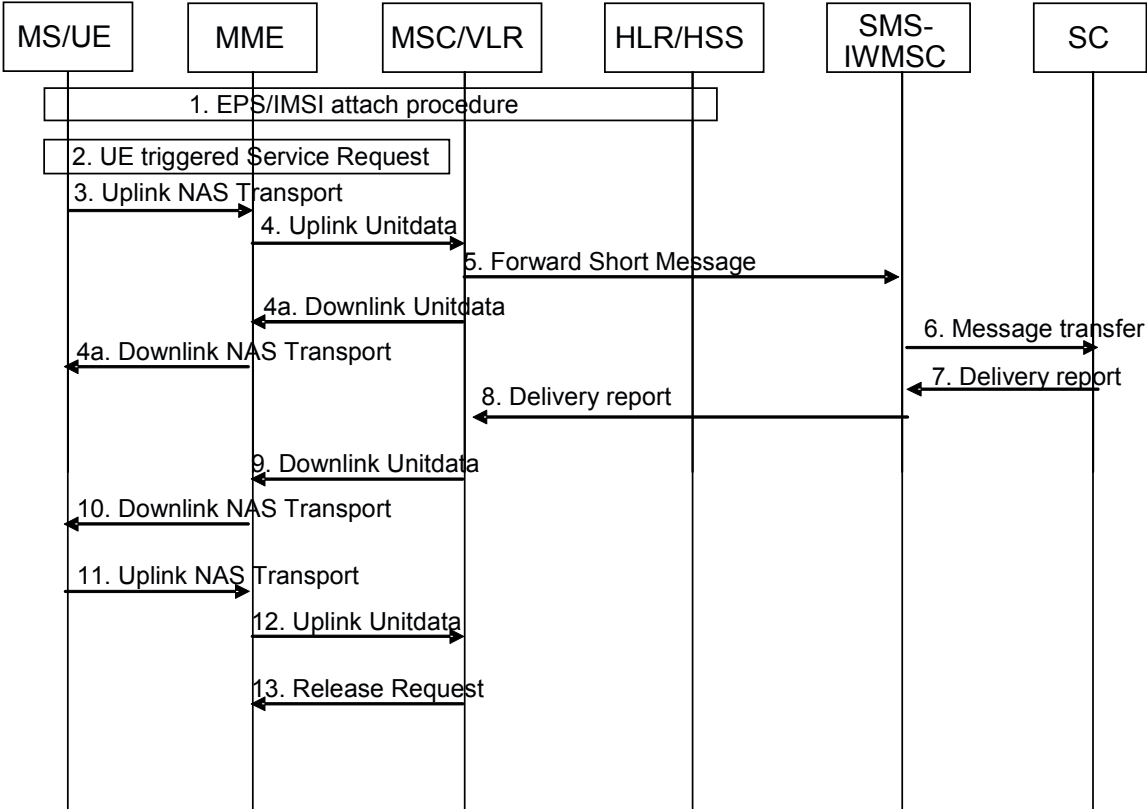
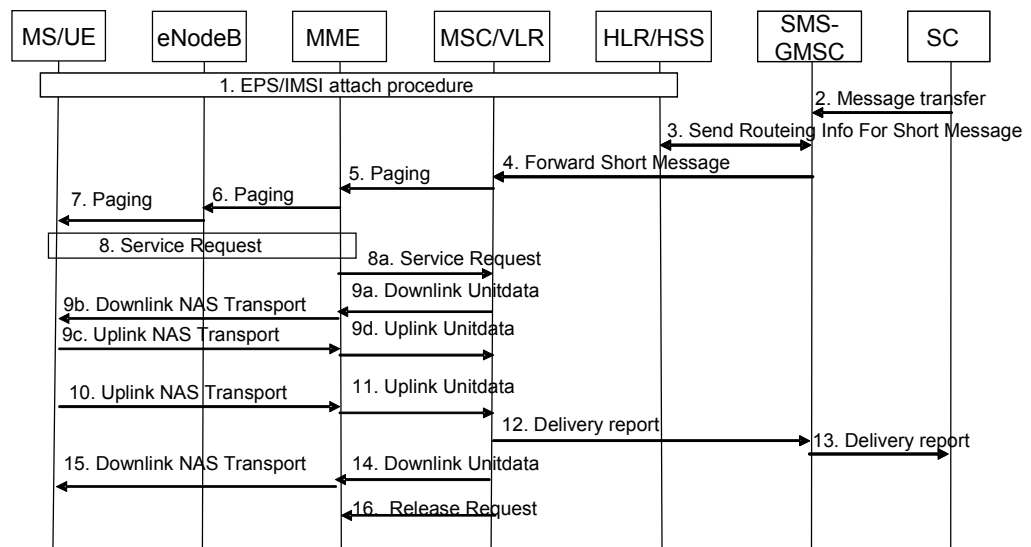

Figure 11: Mobile originating SMS in idle mode [5]

After the EPS/IMSI attach, the UE triggers a service request to initiate a mobile originated SMS procedure. The SMS is encapsulated in a NAS message and sent to the MME. The MME forwards the SMS to the MSC/VLR that acknowledges the receipt of the SMS to the UE. The SMS is forwarded to the SC that returns a delivery report message. The delivery report message is forwarded back to the UE. The UE acknowledges the receipt of the delivery report to the MSC/VLR, and the MSC/VLR indicates to the MME that no more NAS messages need to be tunnelled.

Figure 12 shows the delivery of a mobile terminating SMS in idle mode. The SMS-GMSC is the “gateway MSC for SMS” capable of receiving an SMS from a service center, interrogating an HLR for routing information and SMS info, and forwarding the SMS.



**Figure 12: Mobile terminating SMS in idle mode [5]**

The service center initiates the transfer of the SMS. The HLR is requested for the routing number for SMS services, and the SMS is forwarded to the right MSC/VLR where the UE is attached. The MSC/VLR issues a paging to the MME, and the MME initiates a paging to each LTE base station with cells in the tracking area(s) in which the UE is registered. Upon successful paging, the UE sends a SERVICE REQUEST message to the MME who issues a service request to the MSC/VLR. The MSC/VLR builds the SMS and forwards it to the MME which encapsulates the SMS in a NAS message to the UE. The UE acknowledges the receipt of the SMS to the MSC/VLR and issues a delivery report. The delivery report is forwarded to the service center. The MSC/VLR acknowledges the receipt of the delivery report to the UE and indicates to the MME that no more NAS messages need to be tunnelled.

## 5 Support of voice and SMS via IMS

The IMS is an access-independent and standard-based IP connectivity and service control architecture. It provides the framework for IP-based multimedia services in a mobile network and is an optimum choice to offer voice over IP services. For the sake of this white paper, we are focusing on voice and messaging services over IMS, but please be aware that there is much more to IMS than just that. IMS was first specified in 3GPP release 5 and enhanced in the following 3GPP releases to a powerful feature set supporting a wide range of multimedia applications. On the other hand, IMS specifications have become quite complex, as they contain a wide range of options. Among other reasons, this has delayed the commercial deployment of IMS. Now however, more and more commercial IMS deployments are taking place.

Today, the mobile industry considers IMS as the major solution for supporting voice and SMS services in LTE. A Voice over IMS profile was defined that only contains those network and terminal features that are considered essential for launching IMS based voice. The “One Voice” alliance of several major network operators and manufacturers published their 3GPP-compliant Voice over IMS profile recommendations in November 2009 [13]. Complying to this profile is the prerequisite for interoperability of different manufacturer’s terminal and network implementations.

Based on this work, the network operator organization GSMA (Global System for Mobile Communications Association) announced the launch of the Voice over LTE initiative in February 2010 [3]. From this press release, the motivation for VoLTE is cited as follows:

“Using IP Multimedia Subsystem specifications developed by 3GPP as its basis, GSMA have expanded upon the original scope of One Voice work to address the entire end-to-end voice and SMS ecosystem by also focusing on Roaming and Interconnect interfaces, in addition the interface between customer and network. GSMA VoLTE will develop the function and technical definitions for the way in which Voice and SMS will work in the future, and will define the interfaces for an end-to-end calling structure that will take into account interconnect and roaming.”

Proper consideration of the roaming and interconnect issues will be key to the success of voice over IMS in LTE. From experience with legacy technologies, subscribers are used to seamless service availability and worldwide access to voice and messaging services.

GSMA published the IMS profile for Voice and SMS (GSMA Permanent Reference Document IR.92, [14]) based on the profile specified by the One Voice alliance. Only the essential set of terminal and network features for supporting voice and SMS services via IMS is listed; the required IMS functions, supplementary services, media characteristics and radio and packet core capabilities. At a later point, more features may be added to terminals and networks. Compatibility between early VoLTE implementation and later releases shall always be ensured.

The first LTE networks are unlikely to offer nationwide coverage. Therefore, the continuity of voice calls needs to be guaranteed by handover to a legacy technology such as GSM. This is achieved by a feature called single radio voice call continuity (SRVCC).

The following section contains a short overview of the IMS architecture and features relevant for supporting voice and SMS in LTE. Single radio voice call continuity (SRVCC) is also explained. For a detailed introduction to IMS, please see [15].

## 5.1 Overview of the IMS framework

The IMS reference architecture is shown in Figure 13, including interfaces towards legacy networks and other IP multimedia networks. This architecture provides entities for session management and routing, service support, data bases, and interworking.

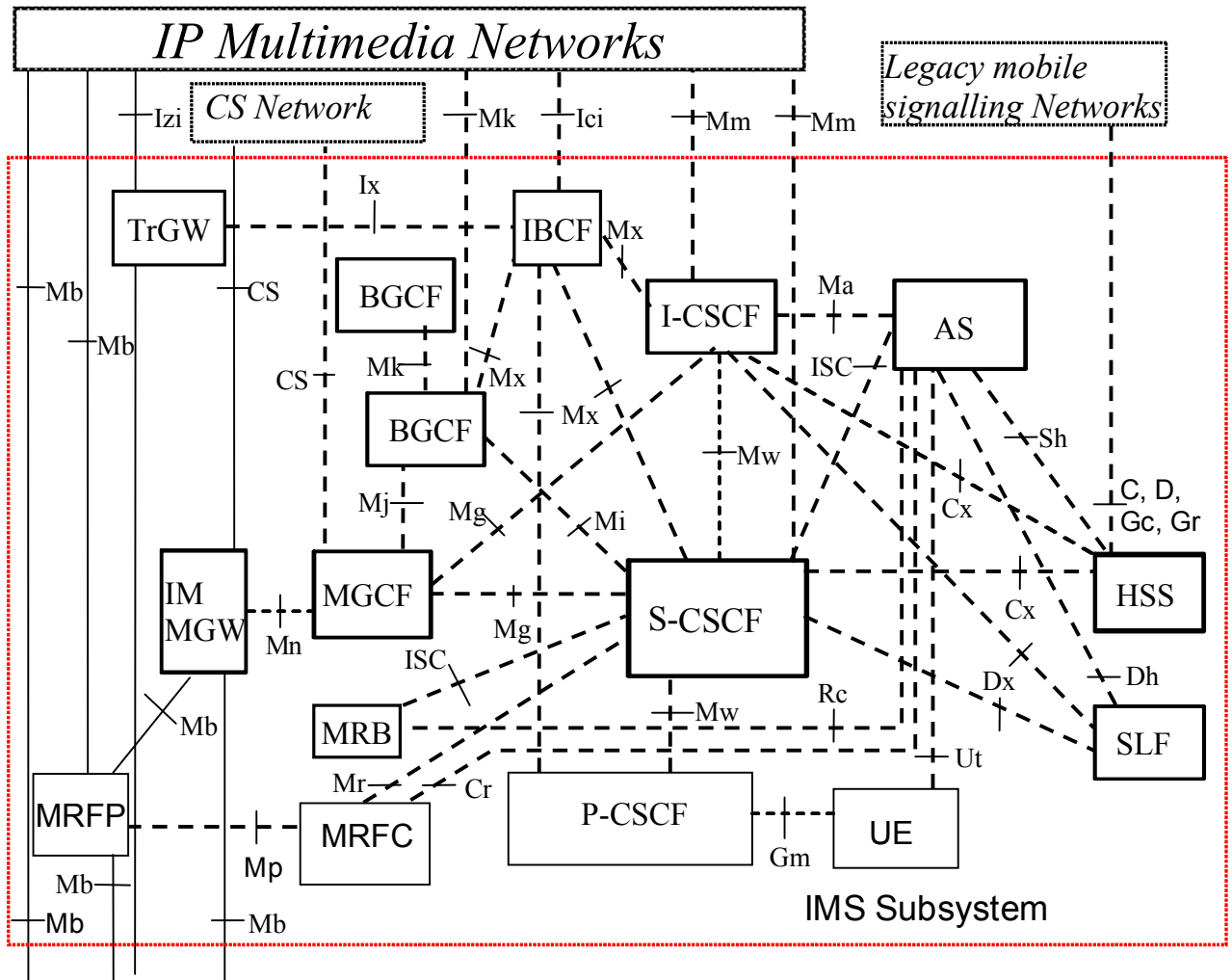
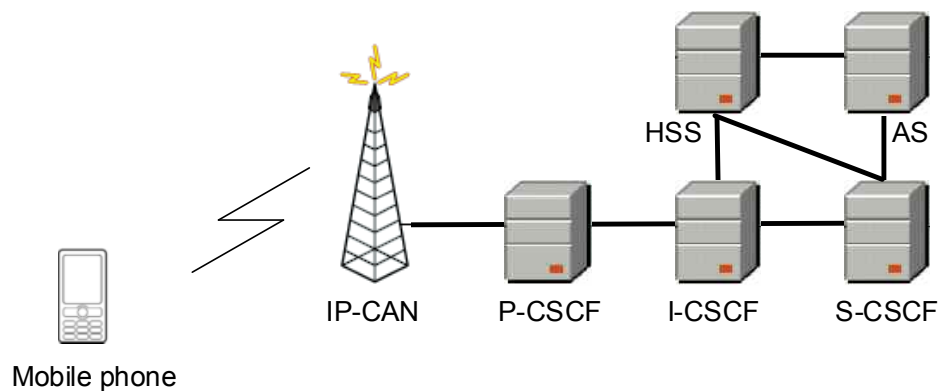

Figure 13: IMS reference architecture [16]

The complexity of the IMS framework becomes obvious, but not all entities and interfaces shown in Figure 13 are required for all use cases. For the sake of this white paper, we will focus only on those entities that are immediately required for understanding the concepts of voice and SMS over IMS. See Figure 14 for a much reduced view on the IMS architecture.



**Figure 14: Schematic view of a part of the IMS architecture**

For LTE, the IP connectivity access network (IP-CAN) as shown in Figure 14 would be composed of the EPS and the E-UTRAN.

The **call session control functions (CSCF)** are the core components of the IMS. There are three CSCF:

- **Proxy-CSCF (P-CSCF):** The P-CSCF is the first point of contact for a user. The P-CSCF behaves like a proxy, i.e. it accepts requests and forwards them on.
- **Interrogating-CSCF (I-CSCF):** The I-CSCF is the entry contact within an operator's network for all connections destined to a subscriber.
- **Serving-CSCF (S-CSCF):** The S-CSCF is responsible for handling the registration process, making routing decisions, maintaining sessions, and downloading user information and service profiles from the HSS.

The **home subscriber server (HSS)** is the master database for a user. It is comparable to the home location register in a legacy mobile radio network. The HSS contains the subscription-related information required for the network entities actually handling calls/sessions. For example, the HSS provides support to the call control servers to complete the routing/roaming procedures by solving authentication, authorisation, naming/addressing resolution, location dependencies, etc.

The **application server (AS)** provides specific IP applications, e.g. messaging.

The purpose of the IMS architecture and the different CSCF entities becomes clear in the case of roaming: Network providers are unwilling to disclose their internal network structure and want to prevent any access to their own user databases. Since a UE always communicates with the local P-CSCF in the accessed network, this P-CSCF must be denied access to the HSS. The I-CSCF is in charge of hiding the network architecture from other providers.

IMS uses a set of internet-based protocols. For the scope of this paper, the following protocols need be mentioned:

- The Session Initiation Protocol (SIP) as a text-based protocol for registration, subscription, notification and initiation of sessions.

- The Session Description Protocol (SDP) as a text-based protocol for negotiating session parameters like media type, codec type, bandwidth, IP address and ports, and for media stream setup.
- The Real-Time Transport Protocol (RTP) and RTP Control Protocol (RTCP) for transport of real-time applications (e.g. audio).
- The Extensible Markup Language (XML) Configuration Access Protocol (XCAP). XCAP allows a client to read, write and modify application configuration data, stored in XML format on a server. XCAP maps XML document sub-trees and element attributes to HTTP uniform resource identifiers (URI), so that these components can be directly accessed by HTTP.
- The Dynamic Host Configuration Protocol (DHCP) for configuring IP addresses. There are DHCP protocol versions for IPv4 and IPv6.

As transport protocols, UDP (for messages smaller than 1300 bytes) or TCP can be used.

The following protocol stacks are relevant for the IMS profile for voice as outlined in GSMA IR.92 [14]:

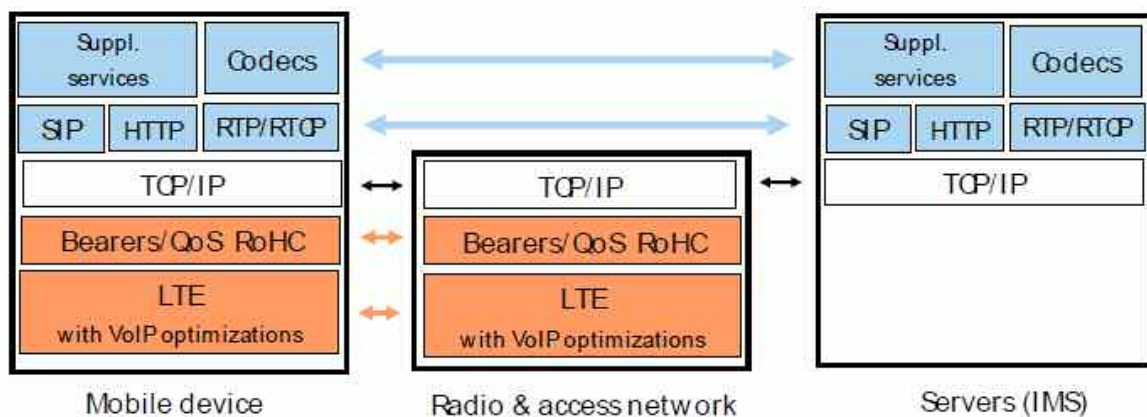

**Figure 15: Depiction of UE and network protocol stacks in IMS Profile for Voice [14]**

In Figure 15, TCP/IP includes the User Datagram Protocol (UDP), and HTTP includes XCAP.

Supplementary services are defined in [17]. Support for some of these services is requested by the VoLTE profile stipulated in GSMA IR.92 [14]. For example, the Originating Identification Presentation (OIP) service provides the terminating user a way to receive identity information to identify the originating user. Another example would be the supplementary service Communication Hold (HOLD) that enables a user to suspend the reception of media stream(s) from an established IP multimedia session, and resume them at a later time. For supplementary service configuration, support of XCAP is required on both the UE and the network side. XCAP in this case is used for manipulating the data related to supplementary services.



For IPv4, the IP address is received as part of the ACTIVATE DEFAULT EPS BEARER CONTEXT REQUEST (in the information element PDN address) in the ATTACH ACCEPT. For IPv6, the UE is first assigned an interface identifier in the ACTIVATE DEFAULT EPS BEARER CONTEXT REQUEST message, and will derive full IPv6 address(es) in a subsequent procedure carried out between the UE and the PDN Gateway. An IP address can either be obtained with the default EPS bearer setup, or using DHCP.

The UE maintains the IP address obtained so long the UE is connected to the IMS. Either the default EPS bearer or a dedicated EPS bearer may be used for IMS-related SIP signalling. Additional dedicated EPS bearers are set up for the actual established media sessions as voice or video. The EPS bearer for SIP signalling has to remain active throughout the lifetime of the IMS connection.

Another important procedure for initiating the IMS connection is **P-CSCF discovery**, used by the UE to obtain the P-CSCF address. The UE must identify the P-CSCF before performing IMS registration or obtaining any service via IMS, because the P-CSCF is the entry point for all SIP messages sent by the subscriber. Several ways to obtain the P-CSCF address are specified in [19]:

- From the EPS bearer context activation procedure, if the UE requests this within the Protocol Configuration Options information element of the PDN CONNECTIVITY REQUEST message or the BEARER RESOURCE ALLOCATION REQUEST: The network then provides the UE with a prioritized list of P-CSCF IPv4 or IPv6 addresses in the ACTIVATE DEFAULT EPS BEARER CONTEXT REQUEST message or ACTIVATE DEDICATED EPS BEARER CONTEXT REQUEST message.
- From DHCP (v4 or v6) procedures
- From preconfigured P-CSCF data (e.g. stored in the ISIM, see next chapter for an explanation of the ISIM).

### 5.3 IMS registration, authentication and key agreement

The subscriber must perform IMS registration, before IMS services like voice or SMS can be obtained. Registration can be initiated once the UE has established an EPS bearer for IMS signaling, and after P-CSCF discovery has taken place. With registration, the UE's IP address can be connected to the user's public identity as known to other subscribers. The public user identity is a SIP uniform resource identifier (URI) in the format "sip:username@domain", or a TEL URI in the format "tel:<Global Number>". A UE can have several public user identities.



The initial registration procedure consists of the UE sending an unprotected SIP REGISTER request to the P-CSCF. The UE can register any of its public user identities with any IP address acquired by the UE. A user can associate different user identities with different IMS services by including the designated ICSIs (IMS communication service identifier, see below). The P-CSCF then determines the appropriate I-CSCF of the UE's home network using the user identity the subscriber wants to register. The P-CSCF may use either preconfigured entries or DNS procedures. The I-CSCF then contacts the HSS. The HSS stores user preferences and settings and checks whether the user is already registered or whether the user may register in that P-CSCF network. The HSS also stores the associated S-CSCFs. An S-CSCF can be associated with different services and is selected depending on the service to be used. The S-CSCF serves to authenticate the user. The authentication and key agreement (AKA) algorithm known as in UMTS is used to authenticate and generate keys. The S-CSCF acquires the necessary keys from the HSS. Via I-CSCF and P-CSCF it returns an authentication challenge to the UE in the form of a negative reply (401 Unauthorized) to the initial SIP REGISTER request. As soon as the UE has correctly responded to this challenge with another SIP REGISTER request, it has been successfully registered in the IMS, which the S-CSCF confirms by a positive reply. Starting with the second SIP REGISTER, all SIP messages can now be protected for integrity and confidentiality as these keys were derived during the AKA procedure. According to the IMS profile stipulated in GSMA document IR.92 [14], support of integrity protection is required for both the UE and the network, while confidentiality protection is optional, as lower layer security is available.

Figure 17 shows the simplified message flow for IMS registration and authentication.

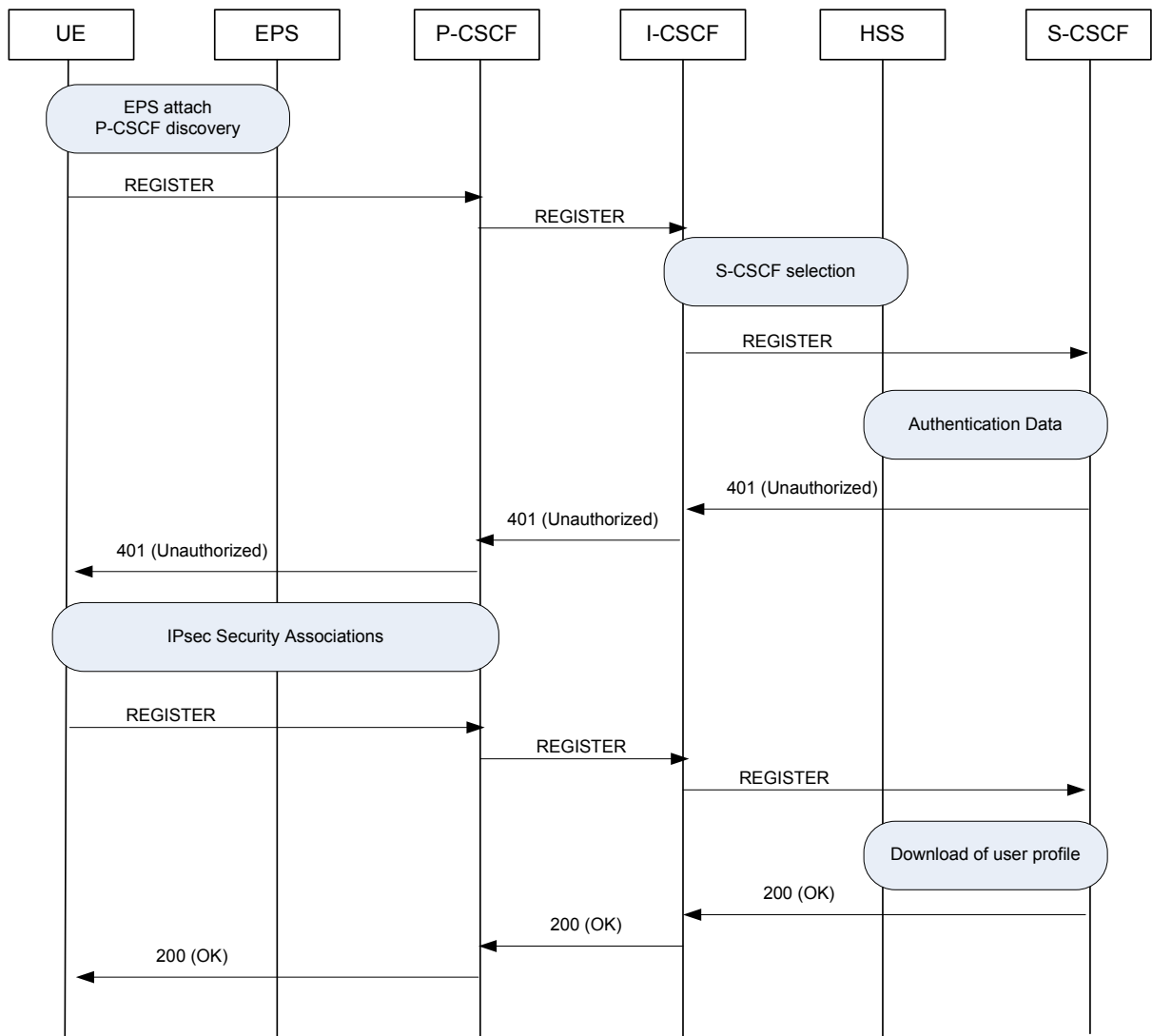

**Figure 17: Initial IMS registration**

Internet Protocol Security (**IPsec**), is a protocol providing secure IP communication. It is used to secure SIP traffic between the UE and the P-CSCF. The only messages sent unprotected in the message flow in Figure 17 are the initial SIP REGISTER and the 401 (Unauthorized). IPsec is based on the user authentication described above and involves the establishment of security associations between the UE and the P-CSCF that define how the communication shall be secured, e.g. algorithms and keys to be used.

IMS authentication is based on the **ISIM** (IP multimedia services identity module). The ISIM is an application on the universal integrated circuit card (UICC) smart card, containing parameters for user identification and authentication. The ISIM is preconfigured with all necessary parameters to initiate IMS registration and authentication. These parameters include:

- the private user identity to identify the user's subscription (comparable to the function of the international mobile subscriber identity (IMSI) used in legacy systems)
- one or more public user identities to identify the user

- the home network domain name to identify the name of the home network during registration and to address the SIP REGISTER request.

If only an universal subscriber identity module (USIM) application is on the UICC, the UE can still register with IMS. The UE derives the required information for authentication from the IMSI.

A UE can be re-authenticated during subsequent re-registrations, de-registrations or registrations of additional public user identities. When the network requires authentication or re-authentication, the UE will receive a 401 (Unauthorized) response to the SIP REGISTER request. The registration expiration interval is typically set to 600,000 seconds (nearly 7 days).

The multimedia telephony communication service shall be associated with a communication service identifier to allow easy identification of the service. To indicate an IMS communication service to the network, UEs are assigned ICSI values according to the IMS communication services supported by the UE. The ICSI values are coded as uniform resource names (URNs), i.e. urn:urn-7:3gpp-service.ims.icsi.mmtel for the multimedia telephony service. According to the IMS profile in GSMA document IR.92 [14], the UE must include this IMS communication service identifier (ICSI) value in the SIP REGISTER message to inform the network about its capabilities.

## 5.4 Obtaining voice services via IMS

Figure 18 shows a mobile originating call. It is initiated by the UE with a SIP INVITE request.

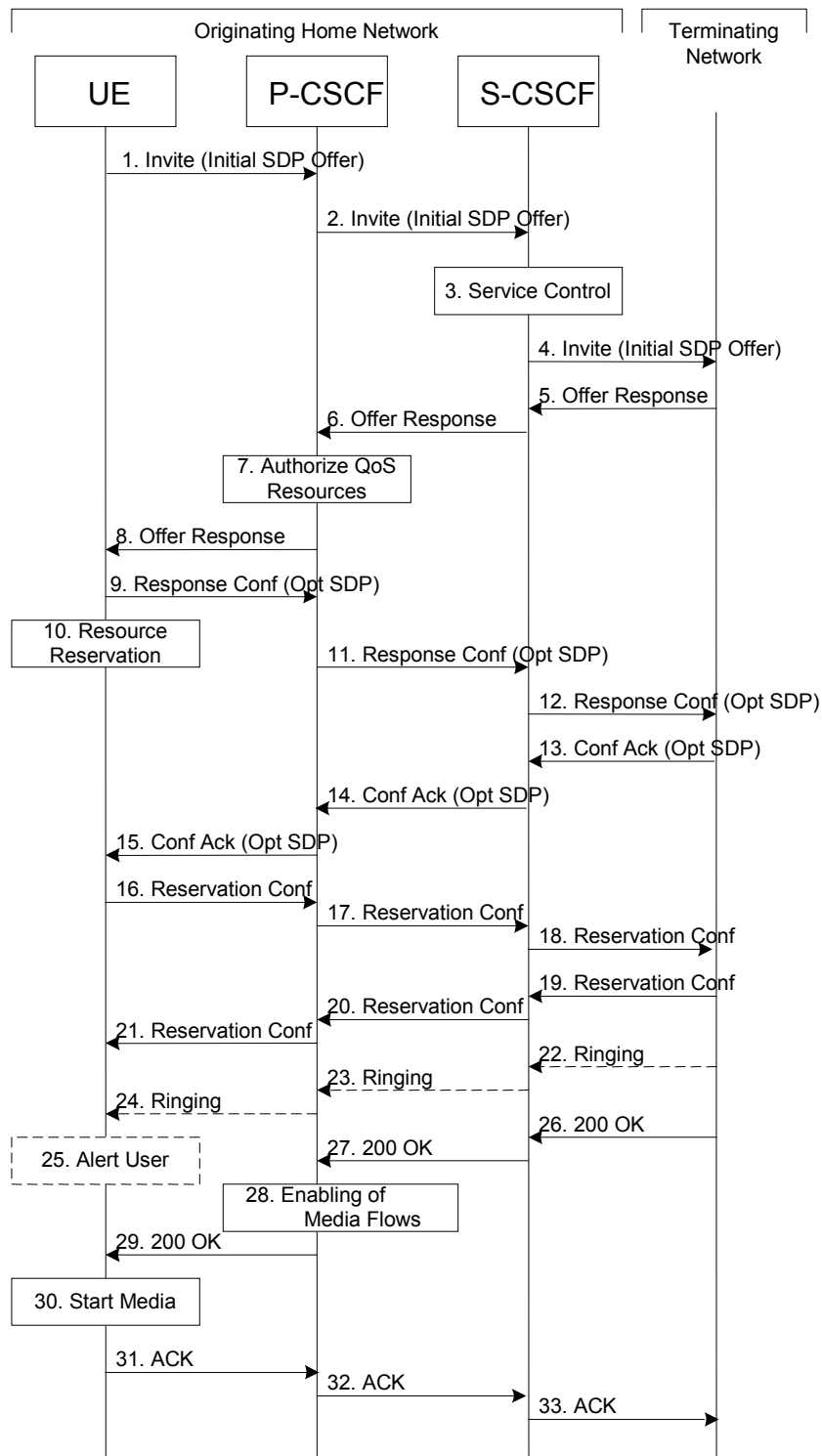

**Figure 18: Mobile origination procedure – home [16]**

This origination procedure applies to users located in their home service area.

The SIP INVITE request contains an initial SDP information, describing one or more media for a multimedia session. The P-CSCF forwards the INVITE to the S-CSCF identified during the registration procedure. The media stream capabilities of the destination are returned. The S-CSCF forwards the Offer Response message received from the terminating network to the P-CSCF authorizing the resources necessary for this session. The P-CSCF forwards the Offer Response message to the originating endpoint. The UE confirms the receipt of the Offer Response message. Depending on the bearer establishment mode selected for the EPS session (UE only or UE/NW), resource reservation is initiated either by the UE or the IP-CAN. This includes the establishment of EPS bearers with the appropriate quality of service. After receiving the confirmation to the initial offer response message, the terminating end point responds to the originating end with an acknowledgement. When the resource reservation is completed, the UE sends the successful Resource Reservation message to the terminating endpoint, via the signalling path established by the INVITE message. The terminating end point responds to the originating end when successful resource reservation has occurred. The destination UE may optionally perform alerting. If so, it signals this to the originating party by a provisional response indicating Ringing. When the destination party answers, the terminating endpoint sends a SIP 200 OK final response along the signalling path to the originating end. The P-CSCF indicates that the media flows authorized for this session should now be available. The UE starts the media flow(s) for the session and responds to the 200 OK with an ACK message which is passed along the signalling path to the terminating end.

The preconditions mechanism is supported by the originating UE according to the IMS profile in [14]. It makes network quality of service a precondition for establishment of sessions initiated by the Session Initiation Protocol (SIP). These preconditions require a participant to use resource reservation mechanisms before beginning the session.

Voice over IMS uses the AMR speech codec with all eight modes, with a baseline profile supporting AMR narrowband. Use of AMR wideband is recommended according to the IMS profile in GSMA document IR.92 [14]. Codec rate adaptation can be used for further optimization.

## 5.5 Radio aspects

For voice traffic, several radio protocol features and optimizations are included to guarantee quality of service and improve efficiency.

The voice service uses the unacknowledged mode (UM) of the radio link control (RLC) protocol to reduce overhead and latency. Early LTE terminals optimized for data services only support RLC acknowledged mode. Dedicated feature group indicators [8] are used by UEs to indicate support of VoLTE as part of the UE capability indication to the network. Besides RLC UM, VoLTE UEs shall also support short packet data convergence protocol (PDCP) and RLC sequence numbers (7 bit for PDCP, 5 bit for RLC), to reduce overall packet size and improve coding efficiency. This is especially important for uplink scenarios, improving coverage of cell-edge users.

Besides the unacknowledged mode radio bearer, the UE has to support signaling radio bearers 1 and 2 (SRB1 and 2) for the dedicated control channel (DCCH). In addition, recommendation IR.92 [14] mandates the support of four acknowledged mode (AM) bearers for the UE (two AM bearers for the network). One of them is used for SIP signalling, and the others are available for IMS traffic.

Each radio bearer has to fulfill quality of service (QoS) characteristics provided by the associated EPS bearer. Each EPS bearer uniquely identifies traffic flows subject to common QoS characterized by the QoS class identifier (QCI) of the EPS bearer. QCI characteristics as specified in [20] are shown in Table 3.

**Table 3: Standardized QCI characteristics [20]**

| QCI | Resource Type | Priority | Packet Delay Budget | Packet Error Loss Rate | Example Services   |
|-----|---------------|----------|---------------------|------------------------|--|
| 1   | GBR           | 2        | 100 ms              | $10^{-2}$              | Conversational Voice   |
| 2   |               | 4        | 150 ms              | $10^{-3}$              | Conversational Video (Live Streaming)  |
| 3   |               | 3        | 50 ms               | $10^{-3}$              | Real Time Gaming   |
| 4   |               | 5        | 300 ms              | $10^{-6}$              | Non-Conversational Video (Buffered Streaming)  |
| 5   | Non-GBR       | 1        | 100 ms              | $10^{-6}$              | IMS Signalling   |
| 6   |               | 6        | 300 ms              | $10^{-6}$              | Video (Buffered Streaming)<br>TCP-based (e.g. www, e-mail, chat, ftp, p2p file sharing, progressive video, etc.) |
| 7   |               | 7        | 100 ms              | $10^{-3}$              | Voice, Video (Live Streaming),<br>Interactive Gaming   |
| 8   |               | 8        | 300 ms              | $10^{-6}$              | Video (Buffered Streaming)<br>TCP-based (e.g. www, e-mail, chat, ftp, p2p file sharing, progressive video, etc.) |
| 9   |               | 9        |                     |                        |  |

The EPS bearer for voice has a QCI = 1 which represents conversational speech characteristics with guaranteed bit rate. The EPS bearer carrying SIP signalling has a QCI of 5 which characterizes a high-priority non-guaranteed bit rate bearer suitable for IMS control messages like SIP signaling and XCAP messages. IR.92 [14] recommends using the default EPS bearer for SIP and XCAP signalling, in order to minimize the number of EPS bearers used. The EPS bearers associated with the acknowledged mode radio bearers have QCI = 8 (interactive traffic with lower traffic handling priority) or QCI = 9 (background traffic).

Due to the IMS multimedia capabilities, voice calls can easily be combined with other sessions, like video streaming or conferencing. This enables much more possibilities for new applications and use cases.

Many additional radio protocol features specified in LTE optimize voice transmission, such as:

- Robust header compression: The robust header compression protocol (ROHC) is located in the PDCP layer. It is used to compress the headers of IP packets to reduce overall packet size.
- Transmission time interval (TTI) bundling to reduce uplink load: an enhancement to the hybrid automatic repeat request (HARQ) retransmission protocol so that the UE can autonomously retransmit packets within a bundle of four subframes without awaiting ACK/NACK.
- Frequency hopping for additional frequency diversity.

- Discontinuous reception (DRX): the UE does not continuously read the physical downlink control channel (PDCCH) for scheduling information, but only in specified intervals.
- Semi-persistent scheduling (SPS): unlike dynamic scheduling, the UE uses a predefined resource for reception and/or transmission and has to read less physical downlink control channel information for scheduling.

## 5.6 Obtaining SMS services via IMS

With SMS-over-IP functionality, the UE can send traditional short text messages over the IMS network. In the IMS network, an IP-Short-Message-Gateway (IP-SM-GW) provides the protocol interworking to submit short messages from the sending UE to the service center, and from the serving center to the receiving UE. It also handles SMS status reports from the serving center to the sender.

Figure 19 shows the message flow for mobile originating SMS. The UE as SM-over-IP sender submits a short message via a SIP MESSAGE request. This request includes the short message, and routing information for the IP-SM-GW to forward the short message. The S-CSCF analyses the request against the initial filter criteria (iFC) and determines whether to send the SIP MESSAGE request to the IP-SM-GW. The initial filter criteria are made available from HSS to S-CSCF during user registration and indicate the user's subscription information, i.e. information about the application server to be contacted and trigger points that should be checked before the application server is contacted. The IP-SM-GW forwards the short message to the service center which returns a submission report. The submission report is sent to the UE in a SIP MESSAGE.

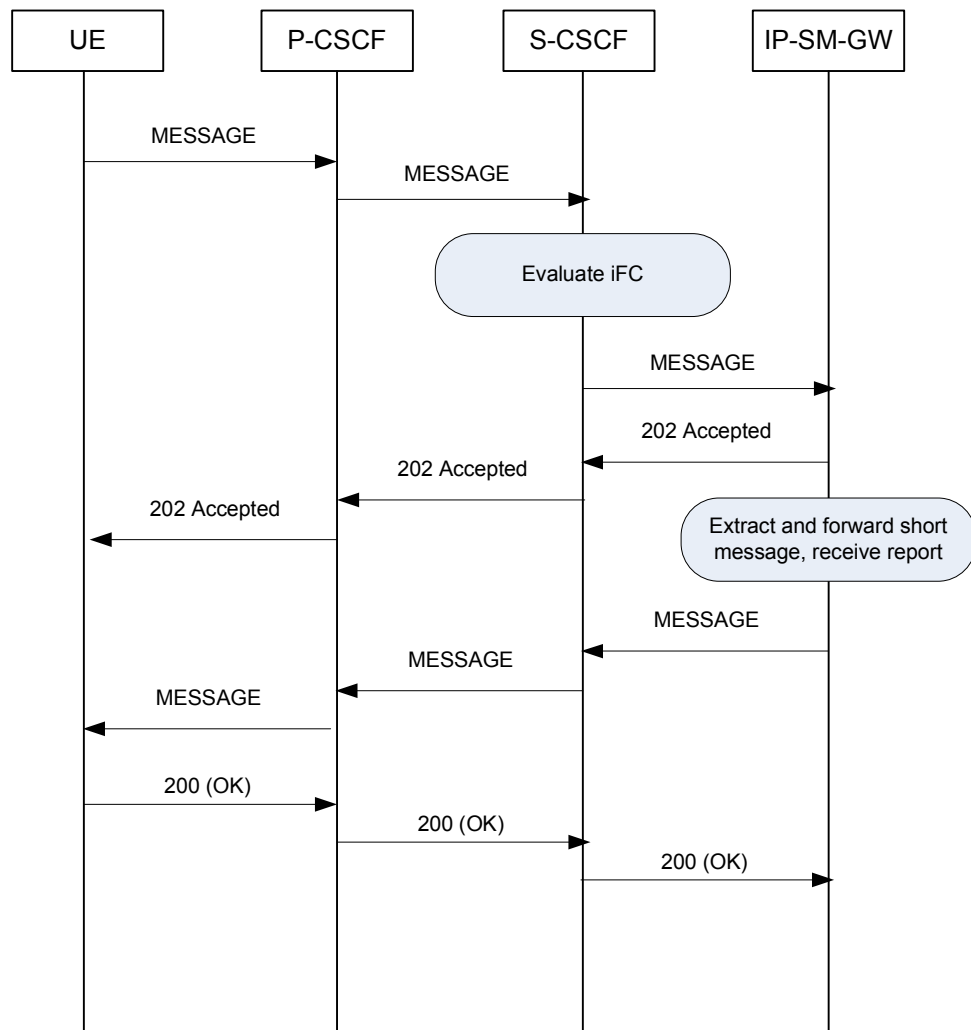

**Figure 19: Mobile originating SMS**

Figure 21 shows the message flow for mobile terminating SMS.



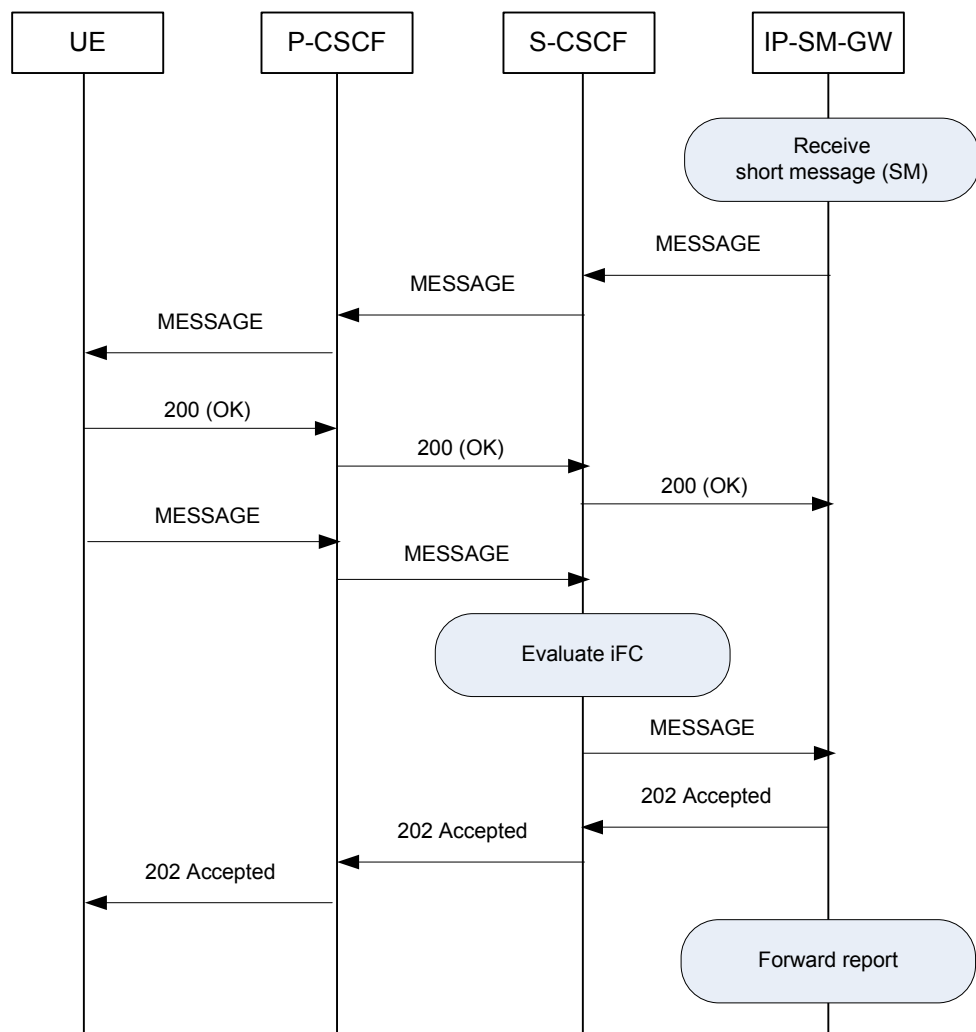

**Figure 20: Mobile terminating SMS**

The IP-SM-GW receives a short message from the service center including routing information for the S-CSCF. The short message is delivered to the UE via SIP MESSAGE requests. The UE then responds with 200 (OK) and issues a delivery report in a SIP MESSAGE request. The S-CSCF analyses the incoming request against the initial filter criteria and determines whether to send the SIP MESSAGE request to the IP-SM-GW. The IP-SM-GW accepts and forwards the delivery report to the service center.

## 5.7 Single radio voice call continuity

Single radio voice call continuity (SRVCC) provides voice call continuity between IMS access in LTE and circuit switched (CS) access of other radio access technologies (CDMA2000®, GSM, or UMTS). Calls remain anchored in IMS, which means that the circuit switched connections can be treated as standard IMS sessions and the circuit switched bearer is used as media for IMS sessions. With SRVCC, the UE only has to be capable of transmitting/receiving on one access network at a given time. SRVCC provides a solution for LTE networks who do not offer nationwide coverage. Circuit switched legacy technologies complement the LTE coverage with voice over IMS support.

SRVCC is built upon the IMS centralized services (ICS) concept for delivering consistent services to the user regardless of the attached access type and for maintaining service continuity for a moving terminal [21]. The call anchoring is by means of a VCC application server in the home IMS network. During EPS attach, routing information to the VCC application server is provided from HSS to MME. During the EPS attach procedure, the network and the UE indicate their support for SRVCC.

Modifications in core network elements are required to support SRVCC. For CDMA2000®, the 1x CS SRVCC interworking solution function (3GPP2 1xCS IWS, see also Figure 5) is required. Tunnelling signalling messages across E-UTRAN, EPS and over the S201 interface to the 3GPP2 1xCS IWS is required to prepare handover and minimize the voice gap.

For GSM and UMTS, modifications to the mobile switching center (MSC) server are required. When the E-UTRAN selects a target cell for SRVCC handover, it needs to indicate to the MME that this handover procedure requires SRVCC. Upon receiving the handover request, the MME triggers the SRVCC procedure with the MSC server. The MSC then initiates the session transfer procedure to IMS and coordinates it with the CS handover procedure to the target cell. Handling of any non-voice PS bearer is by the PS bearer splitting function in the MME. The handover of non-voice PS bearer(s), if performed, is according to a regular inter-RAT PS handover procedure. The handover from E-UTRAN procedure used for PS handover as shown in Figure 4 is used to initiate the SRVCC procedure. When SRVCC takes place, the downlink flow of voice packets is switched towards the CS access leg. The call leg moves from the packet to the circuit switched domain, and the UE switches from VoIP to circuit switched voice.

Figure 21 shows the simplified procedure for SRVCC for GERAN or UTRAN.

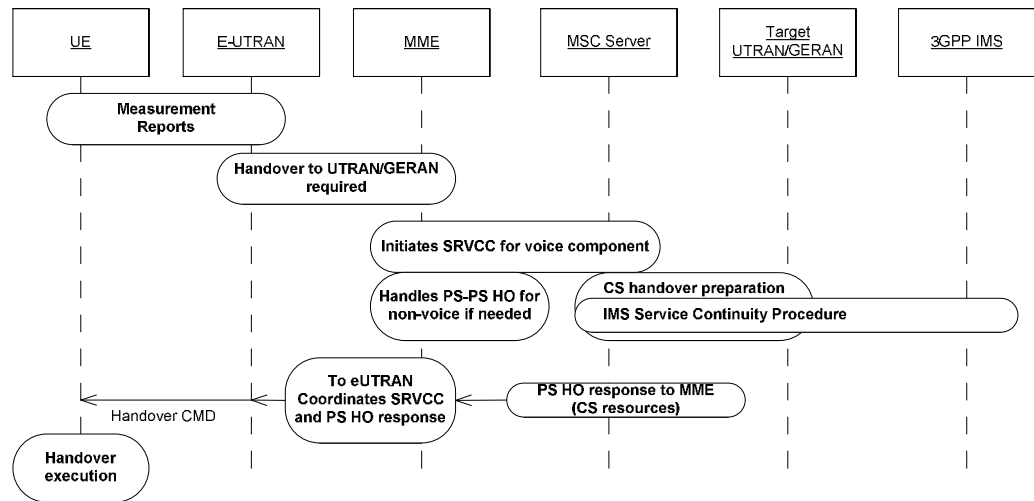

Figure 21: Overall high level concepts for SRVCC from E-UTRAN to UTRAN/GERAN [22]

For SRVCC to GERAN, handover of the voice service and of additional packet switched services is only possible if both the GERAN network and the terminal support dual transfer mode.  
 In 3GPP release 8, SRVCC is supported from E-UTRAN to UTRAN or GERAN, but not in the other direction.

## 6 Test solutions for voice and SMS in LTE

### 6.1 Verifying the terminal protocol stack

Terminals supporting the new features for voice and SMS in LTE need to be thoroughly tested. Verifying the protocol stack of the terminal is of crucial importance in all stages of terminal testing, from early R&D till conformance testing.

For signaling tests, a radio communication tester such as the R&S®CMW500 Wideband Radio Communication Tester that acts as base station simulator is used. It can be configured as protocol tester and supports a wide range of signaling tests for terminals, including R&D scenarios, interoperability test (IOT) scenarios, and conformance test cases.



**Figure 22: The R&S@CMW500 Wideband Radio Communication Tester**

R&D requires flexible test scenarios with individual parameterization at a very early stage of implementing a new feature in a terminal. R&S provides optimized test scenario packages for R&D. For example, the test scenario package R&S@CMW-KF504 “Intra-LTE handover and mobility” contains four test scenarios verifying essential functions for circuit switched fallback operation and SMS over SGs:

- CSFB - Combined attach
- CSFB - Combined tracking area and location area update
- Mobile terminated SMS over SGs
- Mobile originated SMS over SGs

Advanced inter-RAT test scenarios are available as individual options:

- R&S@CMW-KF520 for Mobility and Handover between LTE and GSM
- R&S@CMW-KF530 for Mobility and Handover between LTE and WCDMA
- R&S@CMW-KF588 for Handover between LTE and CDMA2000® 1xEV-DO.

These also include procedures for circuit switched fallback. For example, in R&S CMW-KF530, eight test scenarios addressing CSFB with different variants are included (combinations of mobile terminated and mobile originated calls in idle and active mode, with either redirection or handover from E-UTRAN). An example message flow of a successful test case run is shown in Figure 23 for CSFB to WCDMA with RRC connection release.

| Dir | No.   | Time              | RPN  | Chip  | Layer    | SAP    | Serv                       | Prim | Len[bit] | PDU                                       | Auxiliary                              |
|-----|-------|-------------------|------|-------|----------|--------|----------------------------|------|----------|---|--|
| UP  | 63277 | Jan 12, 2011 1... | 0    | 0     | LAYER... | EPSNAS | RRC_EPS_NAS_DEDICATED_L... | Ind  | 432      | EMM Extended Service Request              | IdType=(P)TMSI;                        |
| DN  | 63291 | Jan 12, 2011 1... | 6613 | 6     | RRC      | CRRC   | CRRC_DL_DCCH_MESSAGE       | Req  | 400      | RRC ConnectionRelease                     |  |
| UP  | 63743 | Jan 12, 2011 1... | 7725 | 15616 | RRC      | CRRC   | CRRC Peer Message          | Req  | 616      | RRC ConnectionRequest                     | Event=OK, RB=0, TMUM+CCCH;             |
| DN  | 63771 | Jan 12, 2011 1... | 7728 | 17920 | RRC      | CRRC   | CRRC Peer Message          | Req  | 1208     | RRC ConnectionSetup                       | RB=0, TMUM+CCCH;                       |
| UP  | 64075 | Jan 12, 2011 1... | 7802 | 2304  | RRC      | CRRC   | CRRC Peer Message          | Ind  | 1560     | RRC ConnectionSetupComplete               | Event=OK, RB=2, AM+DCCH;               |
| UP  | 64118 | Jan 12, 2011 1... | 7809 | 34816 | RRC      | CRRC   | CRRC Peer Message          | Ind  | 686      | InitialDirectTransfer                     | Event=OK, RB=3, AM+DCCH, high;         |
| UP  | 64153 | Jan 12, 2011 1... | 0    | 0     | RRC      | Info   | NAS Direct Transfer        | Ind  | 448      | RR Page Response                          | IdType=IMS;                            |
| DN  | 64166 | Jan 12, 2011 1... | 0    | 0     | RRC      | Info   | NAS Direct Transfer        | Req  | 552      | MM Authentication Req                     |  |
| DN  | 64172 | Jan 12, 2011 1... | 7819 | 33792 | RRC      | CRRC   | CRRC Peer Message          | Req  | 752      | DownlinkDirectTransfer                    | RB=3, AM+DCCH, high;                   |
| UP  | 64232 | Jan 12, 2011 1... | 7836 | 3840  | RRC      | CRRC   | CRRC Peer Message          | Ind  | 1040     | InitialDirectTransfer                     | Event=OK, RB=3, AM+DCCH, high;         |
| UP  | 64236 | Jan 12, 2011 1... | 0    | 0     | RRC      | Info   | NAS Direct Transfer        | Ind  | 784      | GMM Routing Area Update Req               | UpdType=RA updating, IdType=(P)M/TMSI; |
| UP  | 64305 | Jan 12, 2011 1... | 7857 | 34560 | RRC      | CRRC   | CRRC Peer Message          | Ind  | 576      | UplinkDirectTransfer                      | Event=OK, RB=3, AM+DCCH, high;         |
| UP  | 64308 | Jan 12, 2011 1... | 0    | 0     | RRC      | Info   | NAS Direct Transfer        | Ind  | 368      | MM Authentication Response                |  |
| DN  | 64335 | Jan 12, 2011 1... | 7863 | 37888 | RRC      | CRRC   | CRRC Peer Message          | Req  | 448      | SecurityModeCommand                       | RB=2, AM+DCCH;                         |
| UP  | 64425 | Jan 12, 2011 1... | 7893 | 34560 | RRC      | CRRC   | CRRC Peer Message          | Ind  | 568      | SecurityModeComplete                      | Event=OK, RB=2, AM+DCCH;               |
| DN  | 64444 | Jan 12, 2011 1... | 0    | 0     | RRC      | Info   | NAS Direct Transfer        | Req  | 272      | CC Setup                                  |  |
| DN  | 64487 | Jan 12, 2011 1... | 7909 | 6704  | RRC      | CRRC   | CRRC Peer Message          | Req  | 472      | DownlinkDirectTransfer                    | RB=3, AM+DCCH, high;                   |
| UP  | 64634 | Jan 12, 2011 1... | 7961 | 34304 | RRC      | CRRC   | CRRC Peer Message          | Ind  | 752      | UplinkDirectTransfer                      | Event=OK, RB=3, AM+DCCH, high;         |
| UP  | 64637 | Jan 12, 2011 1... | 0    | 0     | RRC      | Info   | NAS Direct Transfer        | Ind  | 512      | CC Call Confirmed                         |  |
| DN  | 64683 | Jan 12, 2011 1... | 7971 | 20480 | RRC      | CRRC   | CRRC Peer Message          | Req  | 1128     | RadioBearerSetup                          | RB=2, AM+DCCH;                         |
| UP  | 65225 | Jan 12, 2011 1... | 8149 | 35840 | RRC      | CRRC   | CRRC Peer Message          | Ind  | 584      | RadioBearerSetupComplete                  | Event=OK, RB=2, AM+DCCH;               |
| UP  | 65351 | Jan 12, 2011 1... | 8168 | 9472  | RRC      | CRRC   | CRRC Peer Message          | Ind  | 576      | UplinkDirectTransfer                      | Event=OK, RB=3, AM+DCCH, high;         |
| UP  | 65355 | Jan 12, 2011 1... | 0    | 0     | RRC      | Info   | NAS Direct Transfer        | Ind  | 336      | CC Alerting                               |  |
| UP  | 66662 | Jan 12, 2011 1... | 8521 | 35328 | RRC      | CRRC   | CRRC Peer Message          | Ind  | 576      | UplinkDirectTransfer                      | Event=OK, RB=3, AM+DCCH, high;         |
| UP  | 66665 | Jan 12, 2011 1... | 0    | 0     | RRC      | Info   | NAS Direct Transfer        | Ind  | 336      | CC Connect                                |  |
| DN  | 66675 | Jan 12, 2011 1... | 0    | 0     | RRC      | Info   | NAS Direct Transfer        | Req  | 272      | CC Connect Ack                            |  |
| DN  | 66679 | Jan 12, 2011 1... | 8524 | 14080 | RRC      | CRRC   | CRRC Peer Message          | Req  | 472      | DownlinkDirectTransfer                    | RB=3, AM+DCCH, high;                   |
| DN  | 66728 | Jan 12, 2011 1... | 0    | 0     | RRC      | Info   | NAS Direct Transfer        | Req  | 280      | GMM Identity Req                          | IdType=IMS;                            |
| DN  | 66740 | Jan 12, 2011 1... | 8535 | 1792  | RRC      | CRRC   | CRRC Peer Message          | Req  | 480      | DownlinkDirectTransfer                    | RB=3, AM+DCCH, high;                   |
| UP  | 66657 | Jan 12, 2011 1... | 8561 | 35328 | RRC      | CRRC   | CRRC Peer Message          | Ind  | 648      | UplinkDirectTransfer                      | Event=OK, RB=3, AM+DCCH, high;         |
| UP  | 66660 | Jan 12, 2011 1... | 0    | 0     | RRC      | Info   | NAS Direct Transfer        | Ind  | 408      | GMM Identity Response                     | IdType=IMS;                            |
| DN  | 66905 | Jan 12, 2011 1... | 0    | 0     | RRC      | Info   | NAS Direct Transfer        | Req  | 576      | GMM Authentication and Ciphering Req      |  |
| DN  | 66910 | Jan 12, 2011 1... | 8571 | 10240 | RRC      | CRRC   | CRRC Peer Message          | Req  | 776      | DownlinkDirectTransfer                    | RB=3, AM+DCCH, high;                   |
| UP  | 67282 | Jan 12, 2011 1... | 8618 | 2048  | RRC      | CRRC   | CRRC Peer Message          | Ind  | 624      | UplinkDirectTransfer                      | Event=OK, RB=3, AM+DCCH, high;         |
| UP  | 67286 | Jan 12, 2011 1... | 0    | 0     | RRC      | Info   | NAS Direct Transfer        | Ind  | 384      | GMM Authentication and Ciphering Response |  |
| DN  | 67338 | Jan 12, 2011 1... | 8623 | 38144 | RRC      | CRRC   | CRRC Peer Message          | Req  | 480      | SecurityModeCommand                       | RB=2, AM+DCCH;                         |

Figure 23: Analysis of message flow for circuit switched fall back to WCDMA

All the test scenario packages for R&S@CMW500 are continuously being enhanced to the latest protocol stack functionality.

As well as test scenarios for R&D, mobile network operators also have a need for intense interoperability testing (IOT) with terminals to be used on the network. Any terminal implementation errors or interoperability issues should be detected as early as possible, i.e. at best before field trials take place. Special interoperability test scenario packages for the R&S@CMW500 radio communication tester address this requirement. They provide terminal interoperability test in the lab, under reproducible conditions. The test requirements are driven by the need to verify terminal behavior in realistic scenarios and to prepare interoperability tests with live base stations and networks from different manufacturers.

An example for interoperability test scenarios is the package R&S@CMW500-KF576 with Verizon Wireless IOT test scenarios. This package will contain SMS over IMS tests.

Besides these R&D and IOT scenarios, 3GPP defines a complete range of signaling tests for terminal conformance testing. These test cases form the basis for terminal certification (by the Global Certification Forum (GCF), for example). Conformance test cases for CSFB and SMS over SGs are defined in [23].

For IMS, the 3GPP RAN5 working group started to specify test cases for the conformance of the basic IMS functionality of mobile devices early in 2006. These conformance test cases are available in testing and test control notation – version 3 (TTCN-3) test specification language. GCF has already included these test cases in its mobile device certification program. The R&S@CMW500 supports the necessary IP protocols for IMS procedures, e.g. SIP, SDP, DNS, DHCP, and includes IPv6 support. It has been the only validated test platform for IMS conformance testing since 2008.

Conformance test for IMS functions is available with Rohde & Schwarz protocol testers with the R&S@CA-AC05 product.

The test cases in R&S@CA-AC05 cover registration and authentication procedures, P-CSCF discovery and specific error cases, for example. An integrated development environment including editor, compiler and execution environment is provided. Realtime examination of the signaling procedure between the mobile device and the protocol tester takes place. For example, a message sequence chart is set up and continuously updated.

The screenshot displays the Rohde & Schwarz IMS CC Conformance Test Case Editor. The interface includes a 'Test Project Description' tree on the left, a central 'IMS CC Message Flow' diagram, and a detailed message comparison table at the bottom.

**IMS CC Message Flow Table:**

| Message ID | IMS CC Server                                     | Direction | IMS CC DUT                                 |
|------------|---|-----------|--|
| 24         | [SP-Codec] Decode                                 | ←         | [Server] A 431 byte long message detected  |
| 24         | Match: [Server] ASP_DataResponse<br>Verdict: PASS |           |  |
| 25         | [pCANctl] ASPCodec Encode                         | →         |  |
| 25         | [pCANctl] DeactivatePDPContextReq                 | →         |  |
| 26         |   |           | [pCANctl] A 351 byte long message detected |

**Message Comparison Table:**

| msg                   | msg                   |
|-----------------------|-----------------------|
| statusLine            | statusLine            |
| sipVersion: "SIP/2.0" | sipVersion: "SIP/2.0" |
| statusCode: 200       | statusCode: 200       |
| reasonPhrase: "OK"    | reasonPhrase: "OK"    |
| msgHeader             | msgHeader             |
| accept omit           | accept *              |
| acceptEncoding omit   | acceptEncoding *      |
| acceptLanguage omit   | acceptLanguage *      |
| alertInfo omit        | alertInfo *           |

Figure 24: Tools for IMS terminal testing

Compare anticipated and received messages with maximum convenience to simplify identifying signaling errors.

The IMS conformance tests are access independent and can be used in conjunction with LTE or WCDMA access technology.

Functionality for SMS over IMS in E-UTRAN also needs to be verified with regards to whether an implementation complies with the specification. SMS over IMS test cases are specified as part of a dedicated 3GPP RAN5 release 8 work item "Conformance test aspects – SMS over IMS in E-UTRAN" launched in September 2009 to extend the existing IMS call control test specification [24]. Two test cases are specified for SMS over IMS (mobile originating and mobile terminating SMS).

Voice over IMS test cases known as MTSI (multimedia telephony service for IMS) test cases are also specified in [24]. An appropriate GCF work item has been launched, focusing on those test cases that correspond to the VoLTE profile.

## 6.2 Voice quality testing

Speech quality is one of the key performance indicators for voice services. Established measurements for evaluating speech quality in circuit switched systems can also be applied for voice over IP, including audio measurements such as PESQ (perceptual evaluation of speech quality), frequency response and distortion measurements. Existing audio test approaches for circuit switched systems such as GSM and CDMA2000® can be extended for VoIP based applications.

See [26] for an example application for VoIP quality testing, based on the radio communication tester R&S®CMW500 and the audio analyzer R&S®UPV. With this setup, tests for the perceptual evaluation of speech quality (PESQ) measurement according to recommendation ITU-T P.862 and some typical audio tests according to 3GPP TS 26.132 [25] can be carried out.

A common feature of all psychoacoustic coding methods is that they utilize the physical properties of human hearing to reduce information in the transmitted signal so that the portions of the signal that would not be perceived are removed from the signal. Speech can be compressed more easily than other types of signals such as music. When speech compression is used, to determine objectively whether the speech transmission technique produces unacceptable degrading of the perceived speech quality, psychoacoustic measuring methods are required.

The PESQ (perceptual evaluation of speech quality) measurement method published by the International Telecommunications Union in 2001 as recommendation ITU-T P.862, enables measurements on speech signals transmitted at low bit rates using high compression psychoacoustic coding methods. PESQ employs an algorithm that enables these signals to be evaluated by comparing them with reference signals. Modern audio analyzers like the R&S®UPV support this measuring method, with software licensed from Opticom GmbH in Erlangen (Germany).

PESQ was developed using a large number of recordings containing sentences spoken by a variety of speakers in a variety of languages. The recordings were made using several different speech encoders with different levels of quality and with typical network transmission disturbances. In a series of listening tests, an adequate number of test listeners classified these examples on a speech quality scale ranging from -0.5 (bad) to 4.5 (excellent).

The goal for PESQ was a method for determining an objective measurement that correlates very well with the listening test results, based on comparing the original, non-degraded speech signal (the reference signal) with the degraded signal (the measured signal). To perform a PESQ measurement, the reference signal is connected to the input of the system under test and the measurement signal is taken from the output of the system under test.

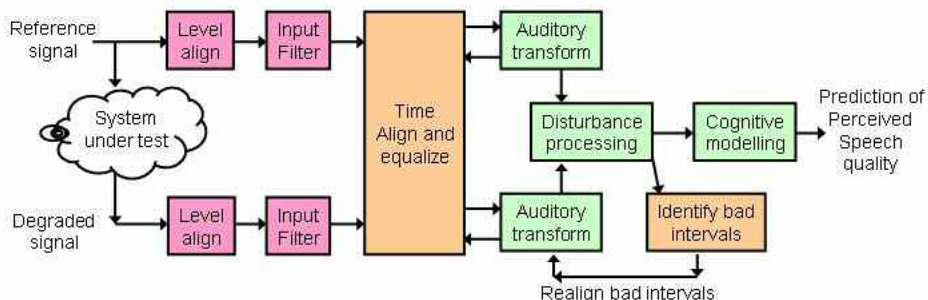

**Figure 25: Algorithm of PESQ measurement in the Audio Analyzer**

The audio analyzer such as the R&S@UPV can also conduct GSM or 3GPP measurements to test specification 3GPP TS 26.132 [25]. For example, these measurements include the send loudness rating (SLR) and receive loudness rating (RLR) as well as distortion measurements. These measurements can also be applied to VoIP connections via other communication standards such as LTE, because they provide a useful characterization of the voice signal.

## 7 Conclusion

Efficient support of voice and SMS is a key requirement for LTE networks. Different techniques to support these services in LTE are introduced in this white paper, from circuit switched fallback to IMS-based solutions. Thorough testing of terminal implementations is a must to verify the proper functioning and performance of the new protocol procedures. Approaches for R&D protocol testing, interoperability testing and conformance testing have been presented, as well as considerations for voice quality testing.

## 8 Literature

- [1] Long Term Evolution – A concise introduction to LTE and its measurement requirements, Christina Gessner, Rohde & Schwarz, ISBN 978-3-939837-11-4
- [2] NGMN Alliance Delivers Operators' Agreement to Ensure Roaming for Voice over LTE, 15 February 2010, [www.ngmn.org](http://www.ngmn.org)
- [3] GSMA VoLTE Initiative, [http://www.gsmworld.com/our-work/mobile\\_broadband/VoLTE.htm](http://www.gsmworld.com/our-work/mobile_broadband/VoLTE.htm)
- [4] 3GPP TS 22.173 V9.5.0 (2010-03): "IP Multimedia Core Network Subsystem (IMS) Multimedia Telephony Service and supplementary services; Stage 1 (Release 9)".
- [5] 3GPP TS 23.272 V9.6.0 (2010-12): "Circuit Switched Fallback in Evolved Packet System; Stage 2 (Release 9)".
- [6] 3GPP TS 36.300 V9.6.0 (2010-12): "Evolved Universal Terrestrial Radio Access (E-UTRA) and Evolved Universal Terrestrial Radio Access Network (E-UTRAN); Overall description; Stage 2 (Release 9)".
- [7] 3GPP TS 36.306 V9.3.0 (2010-09): "Evolved Universal Terrestrial Radio Access (E-UTRA); User Equipment (UE) radio access capabilities (Release 9)".
- [8] 3GPP TS 36.331 V9.5.0 (2010-12): "Evolved Universal Terrestrial Radio Access (E-UTRA); Radio Resource Control (RRC); Protocol specification (Release 9)".



- [9] 3GPP TS 25.331 V7.18.0 (2010-09): „Radio Resource Control (RRC); Protocol Specification (Release 7)“.
- [10] 3GPP TS 24.301 V9.5.0 (2010-12): “Non-Access-Stratum (NAS) protocol for Evolved Packet System (EPS); Stage 3 (Release 9)”.
- [11] 3GPP TS 36.413 V9.5.1 (2011-01): “Evolved Universal Terrestrial Radio Access Network (E-UTRAN); S1 Application Protocol (S1AP) (Release 9)”.
- [12] 3GPP TS 23.060 V9.7.0 (2010-12): “General Packet Radio Service (GPRS); Service description; Stage 2 (Release 9)”.
- [13] One Voice; Voice over IMS profile, V1.0.0 (2009-11)
- [14] GSMA PRD IR.92 - IMS profile for Voice and SMS
- [15] The IMS, IP Multimedia Concepts and Services, M. Poikselka, Georg Mayer, Wiley, ISBN 0470721960
- [16] 3GPP TS 23.228 V9.4.0 (2010-09): “IP Multimedia Subsystem (IMS); Stage 2 (Release 9)”.
- [17] 3GPP TS 24.173 V9.1.0 (2010-03): “IMS multimedia telephony communication service and supplementary services; Stage 3 (Release 9)“.
- [18] 3GPP TS 23.401 V9.7.0 (2010-12): “General Packet Radio Service (GPRS) enhancements for Evolved Universal Terrestrial Radio Access Network (E-UTRAN) access (Release 9)”.
- [19] 3GPP TS 24.229 V9.6.0 (2010-12): “IP multimedia call control protocol based on Session Initiation Protocol (SIP) and Session Description Protocol (SDP); Stage 3 (Release 9)”.
- [20] 3GPP TS 23.203 V9.7.0 (2010-12): “Policy and charging control architecture; Stage 2 (Release 9)“.
- [21] 3GPP TS 23.292 V9.7.0 (2010-09): “ IP Multimedia Subsystem (IMS) centralized services; Stage 2 (Release 9)“.
- [22] 3GPP TS 23.216 V9.6.0 (2010-12): "Single radio voice call continuity (SRVCC); Stage 2 (Release 9)".
- [23] 3GPP TS 36.523-1 V9.3.0 (2010-12): "User Equipment (UE) conformance specification; Part 1: Protocol conformance specification (Release 9)".
- [24] 3GPP TS 34.229-1 V9.3.0 (2010-12) : "Internet Protocol (IP) multimedia call control protocol based on Session Initiation Protocol (SIP) and Session Description Protocol (SDP); User Equipment (UE) conformance specification; Part 1: Protocol conformance specification (Release 9)".
- [25] 3GPP TS 26.132 V9.2.0 (2009-03): “Speech and video telephony terminal acoustic test specification (Release 9)”.
- [26] Rohde & Schwarz Application Note 1MA149 “VoIP Measurements for WiMAX”, [www.rohde-schwarz.com/appnote/1MA149](http://www.rohde-schwarz.com/appnote/1MA149)
- [27] Rohde & Schwarz Application Note 1GA50 “Calibration Tool for PESQ Speech Quality Tests”, [www.rohde-schwarz.com/appnote/1GA50](http://www.rohde-schwarz.com/appnote/1GA50)

## 9 Additional information

Please contact [TM-Applications@Rohde-Schwarz.com](mailto:TM-Applications@Rohde-Schwarz.com) for comments and further suggestions.

## 10 Abbreviations

|          |  |
|----------|--|
| 1xCS IWS | Circuit switched fallback interworking solution function |
| 1xRTT    | 1x radio transmission technology                         |
| 3GPP     | 3 <sup>rd</sup> generation partnership project           |
| AMR      | Adaptive multi rate                                      |
| AS       | Application server                                       |
| BSS      | Base station subsystem                                   |
| CS       | Circuit switched   |
| CSCF     | Call session control function                            |
| CSFB     | Circuit switched fallback                                |
| DHCP     | Dynamic host configuration protocol                      |
| DNS      | Domain name system                                       |
| DRB      | Data radio bearer  |
| DRX      | Discontinuous reception                                  |
| EDGE     | Enhanced data rates for GSM evolution                    |
| EPS      | Evolved packet system                                    |
| E-UTRA   | Evolved universal terrestrial radio access               |
| E-UTRAN  | Evolved universal terrestrial radio access network       |
| FDD      | Frequency division duplex                                |
| GBR      | Guaranteed bit rate                                      |
| GCF      | Global certification forum                               |
| GERAN    | GSM EDGE radio access network                            |
| GPRS     | General packet radio service                             |
| GSM      | Global system for mobile communications                  |
| GSMA     | Global system for mobile communications association      |
| HARQ     | Hybrid automatic repeat request                          |
| HLR      | Home location register                                   |
| HRPD     | High rate packet data                                    |
| HSPA     | High speed packet access                                 |
| HSS      | Home subscriber server                                   |
| HTTP     | Hypertext transfer protocol                              |
| ICS      | IMS centralized services                                 |
| I-CSCF   | Interrogating call session control function              |
| ICSI     | IMS communication service identifier                     |
| IMS      | IP multimedia subsystem                                  |
| IMSI     | International mobile subscriber identity                 |
| IOT      | Interoperability test                                    |
| IP       | Internet protocol  |
| IP-CAN   | IP connectivity access network                           |
| IP-SM-GW | IP short message gateway                                 |
| ISIM     | IP multimedia services identity module                   |
| LTE      | Long term evolution                                      |
| MME      | Mobility management entity                               |
| MSC      | Mobile switching center                                  |

---

|            |   |
|------------|---|
| MTSI       | Multimedia telephony service for IMS          |
| NACC       | Network assisted cell change                  |
| NAS        | Non-access stratum                            |
| NGMN       | Next generation mobile networks               |
| OIP        | Originating identification presentation       |
| PDCCH      | Physical data control channel                 |
| PDCP       | Packet data convergence protocol              |
| PDN        | Packet data network                           |
| PESQ       | Perceptual evaluation of speech quality       |
| P-GW       | Packet data network gateway                   |
| PLMN       | Public land mobile network                    |
| PS         | Packet switched                               |
| P-CSCF     | Proxy call session control function           |
| QCI        | QoS class identifier                          |
| QoS        | Quality of service                            |
| RAN        | Radio access network                          |
| RLC        | Radio link control                            |
| RLR        | Receive loudness rating                       |
| RNS        | Radio network subsystem                       |
| ROHC       | Robust header compression                     |
| RRC        | Radio resource control                        |
| RTCP       | RTP control protocol                          |
| RTP        | Real time transport protocol                  |
| SC         | Service center                                |
| S-CSCF     | Serving call session control function         |
| SCTP       | Stream control transmission protocol          |
| SDP        | Session description protocol                  |
| SIP        | Session initiation protocol                   |
| SGSN       | Serving GPRS support node                     |
| S-GW       | Serving gateway                               |
| SLR        | Send loudness rating                          |
| SMS        | Short message service                         |
| SMS-GMSC   | Gateway MSC for short message service         |
| SMS-IW MSC | Interworking MSC for short message service    |
| SPS        | Semi-persistent scheduling                    |
| SRB        | Signaling radio bearer                        |
| SRVCC      | Single radio voice call continuity            |
| SV-LTE     | Simultaneous voice – LTE                      |
| TCP        | Transmission control protocol                 |
| TDD        | Time division duplex                          |
| TTCN-3     | Testing and test control notation – version 3 |
| TTI        | Transmission time interval                    |
| UDP        | User datagram protocol                        |
| UE         | User equipment                                |
| UICC       | Universal integrated circuit card             |
| UM         | Unacknowledged mode                           |
| UMTS       | Universal mobile telecommunications system    |
| URI        | Uniform resource identifier                   |
| URN        | Uniform resource name                         |
| USIM       | Universal subscriber identity module          |
| UTRAN      | UMTS terrestrial radio access network         |
| VCC        | Voice call continuity                         |
| VLR        | Visitor location register                     |

|       |                                   |
|-------|-----------------------------------|
| VoIP  | Voice over IP                     |
| VoLTE | Voice over LTE                    |
| XCAP  | XML configuration access protocol |
| XML   | Extensible markup language        |

### **About Rohde & Schwarz**

Rohde & Schwarz is an independent group of companies specializing in electronics. It is a leading supplier of solutions in the fields of test and measurement, broadcasting, radiomonitoring and radiolocation, as well as secure communications. Established more than 75 years ago, Rohde & Schwarz has a global presence and a dedicated service network in over 70 countries. Company headquarters are in Munich, Germany.

### **Environmental commitment**

- Energy-efficient products
- Continuous improvement in environmental sustainability
- ISO 14001-certified environmental management system



### **Regional contact**

Europe, Africa, Middle East

+49 89 4129 12345

[customersupport@rohde-schwarz.com](mailto:customersupport@rohde-schwarz.com)

North America

1-888-TEST-RSA (1-888-837-8772)

[customer.support@rsa.rohde-schwarz.com](mailto:customer.support@rsa.rohde-schwarz.com)

Latin America

+1-410-910-7988

[customersupport.la@rohde-schwarz.com](mailto:customersupport.la@rohde-schwarz.com)

Asia/Pacific

+65 65 13 04 88

[customersupport.asia@rohde-schwarz.com](mailto:customersupport.asia@rohde-schwarz.com)

This application note and the supplied programs may only be used subject to the conditions of use set forth in the download area of the Rohde & Schwarz website.

R&S® is a registered trademark of Rohde & Schwarz GmbH & Co. KG; Trade names are trademarks of the owners.

**Rohde & Schwarz GmbH & Co. KG**

Mühlendorfstraße 15 | D - 81671 München

Phone + 49 89 4129 - 0 | Fax + 49 89 4129 - 13777

[www.rohde-schwarz.com](http://www.rohde-schwarz.com)